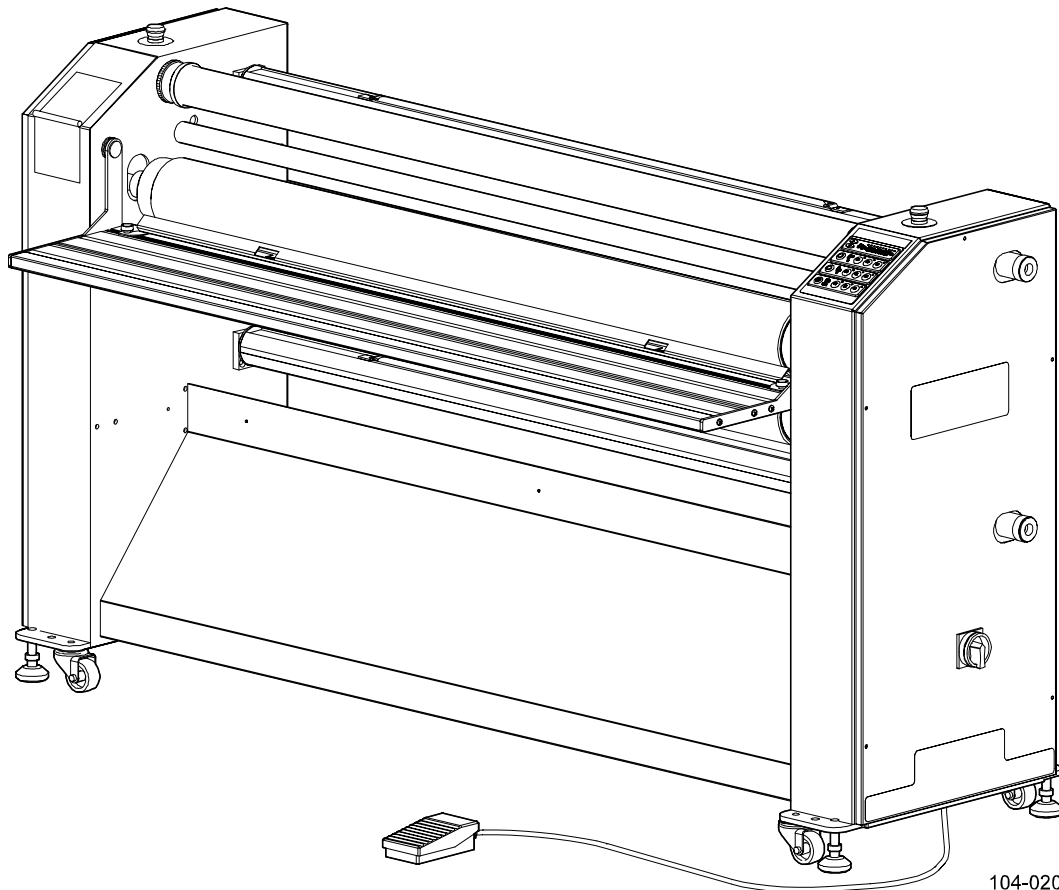

IMAGE 42^{Plus} /62^{Plus}



104-020

English

Français

Deutsch

Español

User manual
Manuel d'utilisation
Betriebsanleitung
Manual de uso

SEAL®

977-0052

English

All rights reserved

All information included in this manual as well as information included in supplements or addendum to this manual is subject to copyright law. This information shall not be used, copied, reproduced, transmitted or disclosed to third parties without our prior written consent.

SEAL Graphics assumes no responsibility for any errors that may appear in this document nor does it make expressed or implied warranty of any kind with regard to this material, including, but not limited to, the implied warranties of merchantability and fitness for a particular purpose.

Seal Graphics shall not be liable for incidental or consequential damages in connection with, or arising out of the furnishing, performance, or use of this document and the program material which it describes.

Français

Tous droits réservés.

Toutes les informations contenues dans ce manuel ainsi que celles des suppléments ou ajouts à ce manuel sont soumis aux lois sur le copyright. Ces informations ne doivent pas être utilisées, copiées, reproduites, transmises ou divulguées à des tiers dans notre autorisation préalable par écrit.

SEAL Graphics n'accepte aucune responsabilité pour toute erreur pouvant apparaître dans ce document et ne donne aucune garantie tacite ou expresse eu égard à ce matériel, y compris mais sans s'y limiter, à toute garantie tacite de qualité marchande ou d'adaptabilité à un usage particulier.

SEAL Graphics n'est pas responsable des dommages accessoires ou indirectes liés à ou découlant de la diffusion, performance ou l'utilisation de ce document et du matériel décrit.

Deutsch

Alle Rechte vorbehalten.

Alle Informationen in diesem Handbuch sowie Informationen in Ergänzungen oder Zusätzen zu diesem Handbuch unterliegen dem Urheberrechtsgesetz. Die Informationen dürfen ohne unsere Genehmigung nicht verwendet, kopiert, wiedergegeben, übertragen oder an Dritte weitergegeben werden.

SEAL Graphics haftet nicht für Fehler, die in diesem Dokument auftreten können, noch übernimmt SEAL Graphics Europe BV keinerlei ausdrückliche oder implizite Garantie in Bezug auf dieses Material, einschließlich, jedoch nicht begrenzt auf die implizierte Garantie der Marktgängigkeit und Eignung für einen bestimmten Zweck.

SEAL Graphics haftet nicht für auftretende oder Folgeschäden in Verbindung mit oder entstehend aus der Ausstattung, Leistung oder Benutzung dieses Dokuments und des Programmmaterials, das es beschreibt.

Español

Reservados todos los derechos.

Toda la información incluida en este manual y en los suplementos a anexos de este manual están sujetas a las leyes de derechos de autor. Queda prohibida la utilización, copia, reproducción, transmisión o divulgación de esta información a terceros sin nuestro consentimiento previo por escrito.

SEAL Graphics no se hace responsable de los errores que pudieran aparecer en este documento ni tampoco ofrece garantía implícita o explícita de ningún tipo en relación con el material descrito, incluyendo, aunque sin que ello constituya un límite, las garantías implícitas de comercialización e idoneidad para una finalidad concreta.

SEAL Graphics no responderá de los daños imprevistos o emergentes relacionados con, o que puedan surgir del suministro, funcionamiento o el uso de este documento y del material de programa que describe.

IMAGE 42^{Plus} /62^{Plus}

English

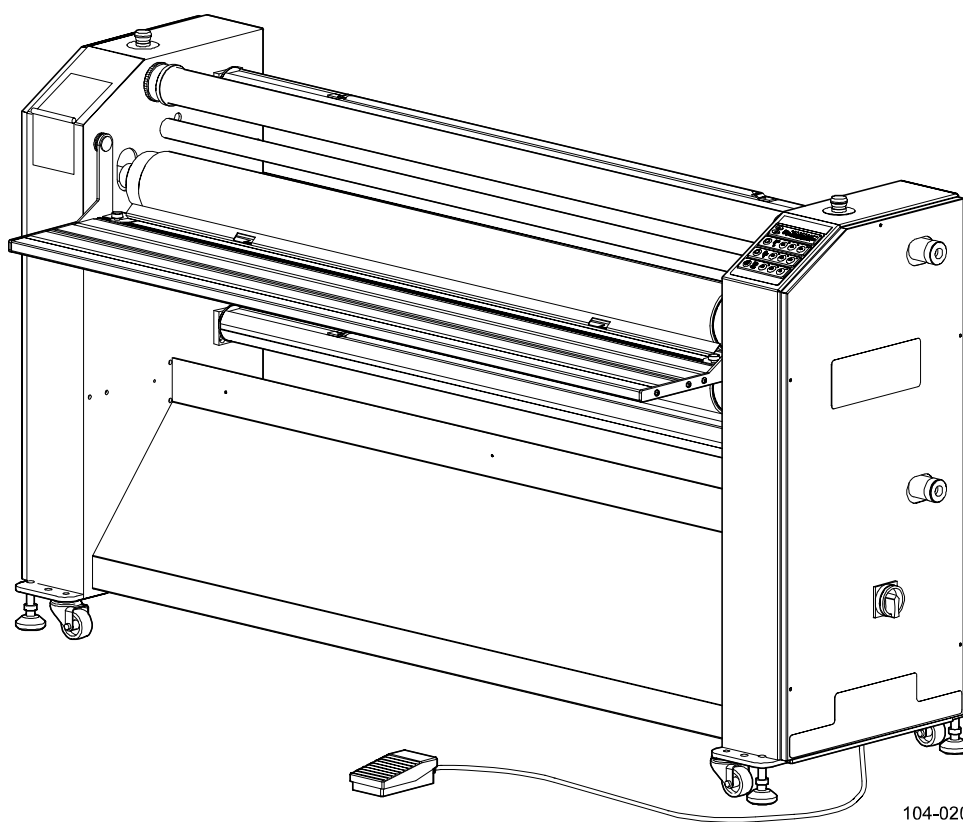

104-020

User manual

UM104EN, Rev. 2.1

September 2002

 **SEAL**®

Limited Warranty on Seal Image Laminators

SEAL Graphics warrant to the original consumer purchaser that all new Seal Image Laminators that prove defective in materials or workmanship within the applicable warranty period will be repaired or, at our option, replaced without charge. The applicable warranty shall be one year from date of purchase with the exception of the silicone roll coverings that will be six months from date of purchase. This warranty does not apply if it is found that at any time the equipment has not been used for its intended purpose.

“Original consumer purchaser” means the person whom first purchased the product covered by this warranty other than for the purpose of resale. The warranty extends to and is enforceable only by the original consumer purchaser, and only for the period (during the applicable term) which the product remains in the possession of the original consumer purchaser.

For more information regarding this warranty, please contact your local distributor.

WARNING: Changes or modifications to this unit not expressly approved by the party responsible for compliance could void the user’s authority to operate this equipment.

NOTE: This equipment has been tested and found to comply with the limits for Class A digital device, pursuant to Part 15 of the FCC Rules. These limits are designed to provide reasonable protection against harmful interference when the equipment is operated in a commercial environment. This equipment generates, uses and can radiate radio frequency energy and, if not installed and used in accordance with this manual, may cause harmful interference to radio communications. Operation of the equipment in a residential area is likely to cause harmful interference, in which case the user will be required to correct the interference at the user’s own expense.

This digital device does not exceed the Class A limit for radio noise emissions from a digital apparatus set out in the Radio Interference Regulations of the Canadian Department of Communications.

Le present appareil numerique n’emet pas de bruits radioelectriques depassant les limites applicables aux appareils numerique de la class A precrites dans le Reglement sur le brouillage radioelectrique edicte par le ministere des Communications du Canada.

WARNING: Any unauthorised changes or modifications to this unit will void the user’s warranty and will transfer health and safety obligations to the user.

Contents

Subject	Page
Limited Warranty on Seal Image Laminators	2
Contents	3
Illustrations.....	4
Introduction	5
Using this manual.....	5
Features and benefits of the Image 42 ^{plus} /62 ^{plus}	6
Safety information	8
Safety features.....	9
General information.....	11
Technical specification	13
Identification.....	13
Operating conditions	13
Uncrating and moving the Image 42 ^{plus} /62 ^{plus}	14
Connecting to the electrical supply.....	16
General use	17
Main switch	18
Control panel.....	19
Emergency stop buttons	23
Loading rolls.....	23
Webbing.....	24
Unwind brakes	25
Roller nip settings.....	26
Equivalent measurements.....	26
Cooling fans	27
Feeding images	27
Laminating and Adhesive coating (Decaling)	28
Mounting	31
Encapsulating	33
Pre-coating.....	36
Temperature and speed settings.....	37
Cleaning and maintenance.....	38
Troubleshooting	40
Glossary of laminating terms.....	41
Accessories.....	42
Addresses	42

En

Illustrations

Subject	Page
Features and benefits of the Image 42 ^{plus} /62 ^{plus}	6
Working space	11
Wood blocks	15
Main switch	18
Control panel.....	19
Emergency stop button	23
In-feed table	24
Unwind brake	25
Mounting / Dismounting image guide	27
Decaling (with liner).....	28
Decaling (without liner).....	28
Webbing film (film + liner)	29
Placing the lower film across the roller faces.....	30
Mounting decals	31
Encapsulating.....	33
Placing the lower film across the roller faces.....	34
Cutting off the leader.....	35
Cleaning the upper roller	38
Cleaning the lower roller.....	39

Introduction

Thank you for purchasing the IMAGE 42^{plus}/62^{plus} laminator, a laminator designed to give you years of reliable service. The IMAGE 42^{plus}/62^{plus} brings a new level of simplicity and ease of use to image finishing.

By following the guidelines outlined in this manual for proper care and maintenance, you can depend on receiving many years of trouble-free profitability from your investment.

Reading this manual will familiarise you with the particular features, operational features and guidelines of your laminator.

The manual includes instructions on various laminating techniques and diagrams that give you the comprehensive information needed for safe, efficient use of your laminator. This basic knowledge provides the foundation for the creative, innovative uses you can build on, as you achieve the basic skills through practice.

The IMAGE 42^{plus}/62^{plus} meets applicable EC Directives (89/392/EEC, including 91/368/EEC, 93/44/EEC and 93/68/EEC) and is ETL listed (UL 1950/EN60950).

En

Using This Manual

Special Markings



WARNING: Please pay special attention to all passages marked this way. This information is vital to the proper use and maintenance of the laminator and to the safety of its users.



Passages marked this way give information on the efficient use of the laminator.

Features and Benefits of the Image 42^{plus}/62^{plus}

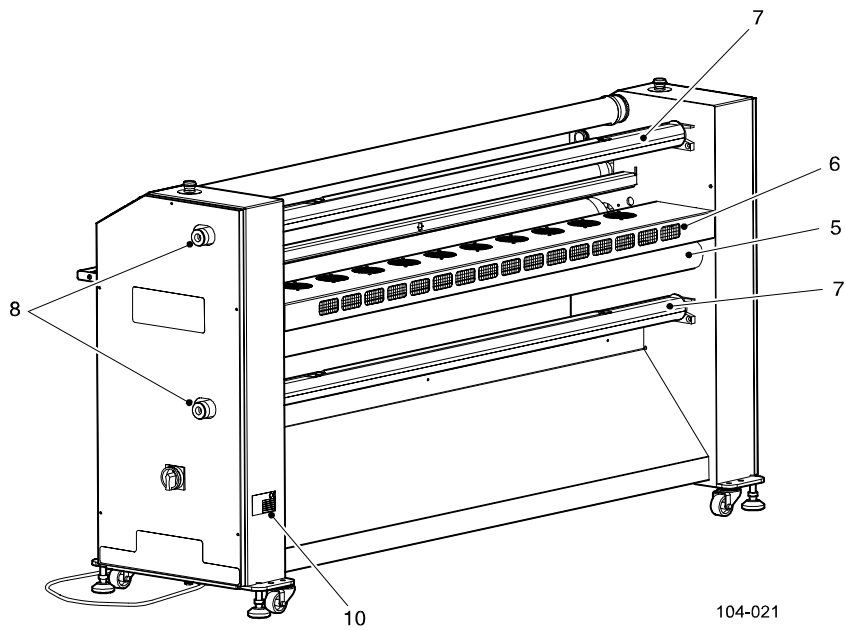
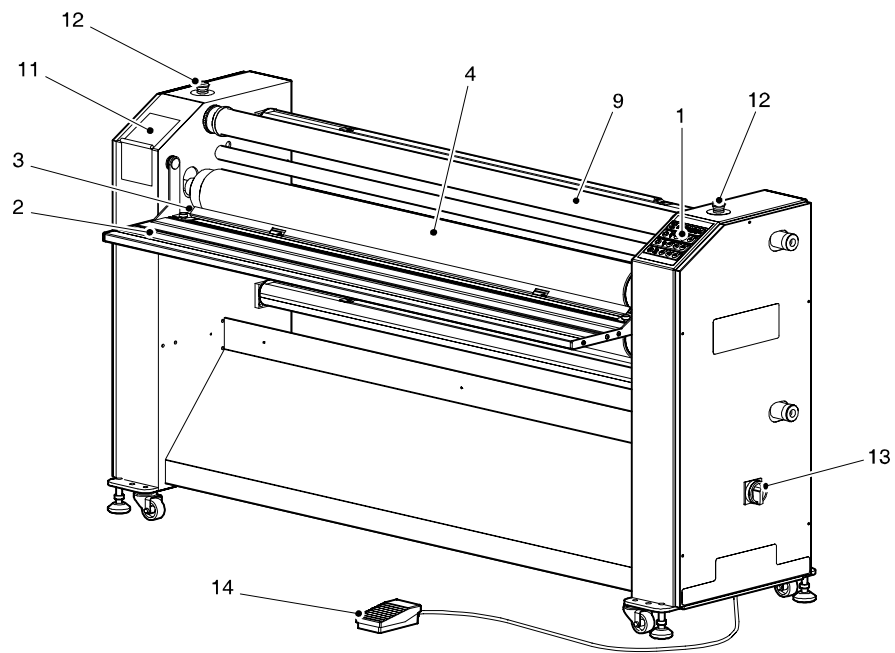

Features and benefits of the Image 42^{plus}/62^{plus}

Features and Benefits of the Image 42^{plus}/62^{plus}

1. **Digital touch pad** control-panel with LED indicators and preset settings for temperature, speed and substrate thickness.
2. **Swinging** in-feed table for easy loading, with integrated Emergency Stop System.
3. **Image guard** to help feed-in images and to prevent paper handling problems, and is removable when mounting.
4. **High-release silicone rollers** prevent adhesive build-up and make cleaning easy.
5. **Anti-static** pull roller to help minimise static build-up.
6. **Automatic fan bank** for efficient film cooling and smooth output during encapsulating.
7. **Pivoting, cantilevered supply shafts** for easy loading and webbing. Both shafts are of the auto-grip design and are mounted on the rear of the machine.
8. **Side mounted unwind brakes** allow easy adjustment of brake tension setting.
9. **Front take-up shaft** for winding up the release liner off some laminates and adhesives.
10. **Identification plate** detailing manufacturing information and CE mark.
11. **Quick reference guide** gives information on recommended films, temperatures, speeds and webbing.
12. **Emergency stop buttons.**
13. **Mains switch.**
14. **Foot switch.**

Also:

Fast, electric heating and independent temperature controls with infra-red control for maximum accuracy.

Sturdy, stand-alone design with fitted castors allow the machine to be easily moved and feet levelled.

Motor-driven, roller-height adjustment system for fast and accurate roller nip setting.

Optional equipment:

Optionally, equipment comprising an unwinding and a winding unit is available.

This allows you to work 'roll to roll'. If you require more information on this matter, please contact your local supplier. This optional equipment is described in the manual 'Image 42^{plus}/62^{plus} roll to roll'.

En

Safety Information

The IMAGE 42^{plus}/62^{plus} laminator is provided with safety equipment to promote safe machine operation. You should however take note of the following:

Read and make sure you understand these safety and operating instructions.

WARNINGS:



Hot surfaces - Danger of getting injured by hot parts.

Be careful with hot parts. The heated rollers can have a surface temperature of up to 120°C (250°F). Do not touch the rollers. Even after the laminator has been switched off the rollers remain hot for a long time.



Rotating parts - Danger of getting injured by rotating parts.

The laminator is equipped with photoelectric eyes and protective plates and covers to avoid contact with the rotating rollers. Make sure that these safety provisions are always in operation/fitted. Make sure that loose clothing, long hair, jewellery and fingers are not caught by the rotating rollers which might result in being trapped.

The motor will stop automatically when the photo-electric eyes in front of the main rollers are interrupted.

This does not happen when the foot switch is being used. In this case the laminator will only work at 0.6 m/min (2"/min) and while the foot switch is being used an audible signal will be heard.



Life electrical parts – Danger of getting injured electric shock.

Do not remove the side panels of the IMAGE 42^{plus}/62^{plus} laminator because there is a danger of getting injured by electricity. Only remove panels to do maintenance. In this case make sure the main electrical supply is off.

Do not put heavy objects on the power supply cable.



Danger of damage to equipment or injury to persons.

This indicates the possibility of damage to equipment or injury to persons if the wrong tools or equipment are used.

Safety Features

- **Photoelectric Safety Eyes** - These self-checking eyes prevent foreign objects from passing in between the rollers. The eyes are set for use at the factory and should not be adjusted except by a service representative.
- **Emergency Stop Buttons** - There are two buttons and they are located on the top of the left and right cabinets of the machine. They stop the rotation of the machine and should only be used in the case of an emergency.
- **Locking Cabinets** - The cabinets which house the inner workings of the laminator can be opened only with a screwdriver.
- **Slow-Mode** - The machine has a so-called slow-mode, which can be activated by pressing the foot switch. To maintain slow-mode, keep the foot switch pressed. Once the machine is running in slow-mode, interrupting the photoelectric eyes **does NOT stop** the machine; an audible beep will be heard, and the roller speed will be 0,6 m/min only. Releasing the foot switch will stop the machine.
- **The rotation of the rollers will stop when:**
 - the photoelectric eyes in front of the main rollers are interrupted.
NOTE: This does NOT happen when the foot switch is used (slow-mode).
 - an emergency stop button is pressed.
 - the foot switch is pressed for a short moment.
 - the input table is lifted.
 - excessive unwind tensions are set (the motor will be shut off electronically, press the stop button on the control panel to reset).
 - the stop button on the control panel is pressed.
 - both 0,6 and 1,2 speed buttons are pressed simultaneously (to reverse the rotation direction of the rollers).

En

Safety Features

- **If the machine is running then:**
 - pressing an emergency stop button will immediately stop the rotation of the rollers. After the emergency stop has been released, the upper roller will move to its MAX opening.
 - lifting the in-feed table will immediately stop the rotation of the rollers. When the in-feed table has been swung back to its normal position, the upper roller will move to its MAX opening.
 - even tipping the in-feed table upwards (with your knee) will stop the rotation of the rollers, and lift the upper roller.
- **If the machine is NOT running then:**
 - pressing the emergency stop buttons or lifting the in-feed table will NOT result in lifting the upper roller.
 - if the upper roller is moving downward (during nip setting) then the upper roller will reverse its movement (goes to MAX opening) when the photoelectric eyes are interrupted at that moment.

WARNING: Use of the inside of cabinets for storage may cause possible injury and/or damage to the inner workings and will void the warranty.

General Information

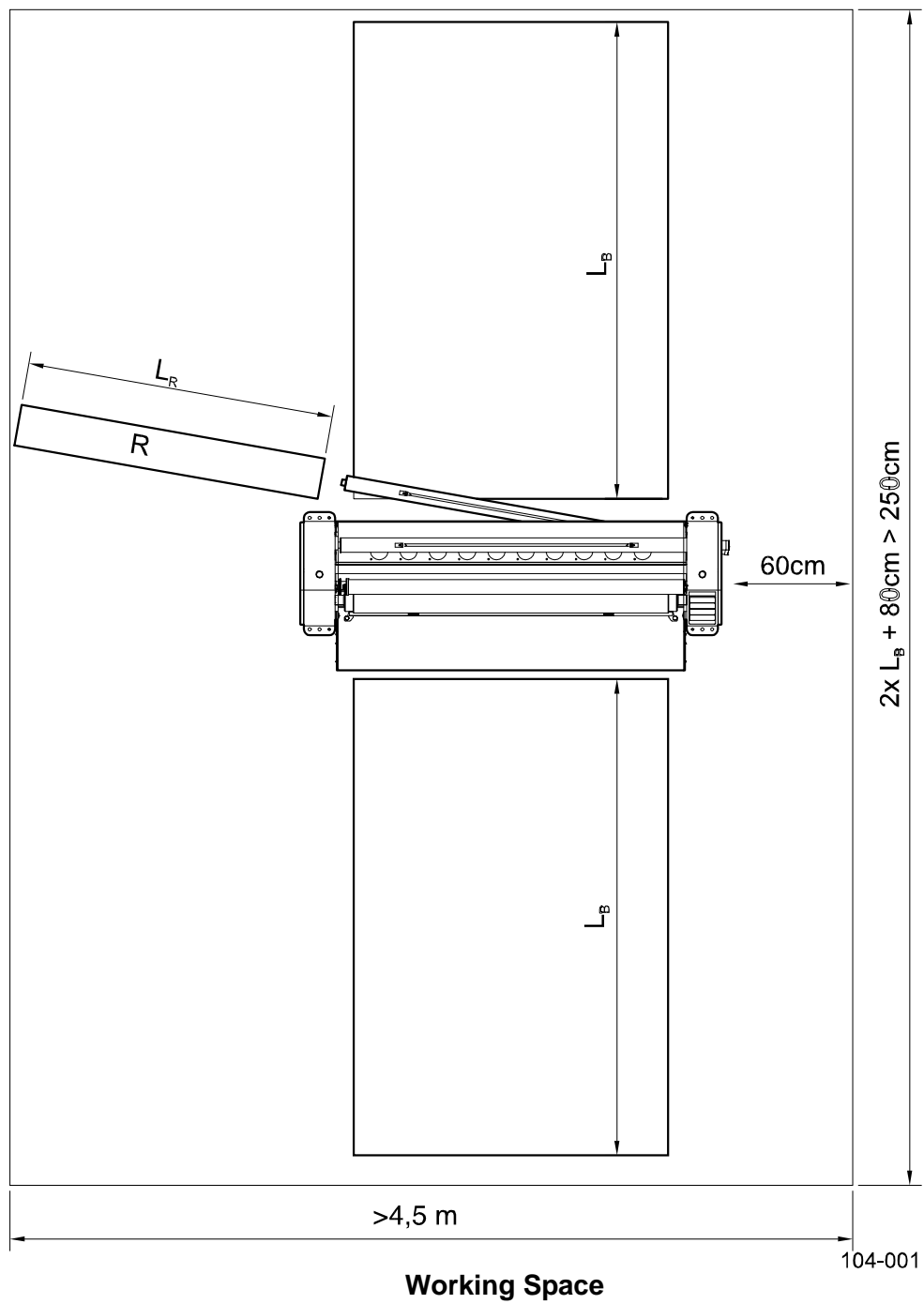

R = Roll

L_R = Roll length (115 cm for Image 42, 160 cm for Image 62)

L_B = Maximum board length

General Information

- **Power Sources** - Only connect the laminator to the power supply specified on the identification label. Refer to the “Specifications” chapter of this manual for more information.
- **Water and Moisture** - Install a RCD (GFI in U.S.A.) in the buildings electrical supply if the laminator is to be used near water or in an area of high humidity.
- **Environment** - Use your laminator in the cleanest, most dust free environment possible to produce the highest quality output. The Image 42^{plus}/62^{plus} consumes approximately 5,5 kW/8 kW of electricity. Because of the heat generated by the machine, the laminator should not be in the same room as an electrostatic plotter, etc.
- **Working Space** - The laminator requires a working area large enough to allow the safe and efficient use. An area 4,5m x 6m would be the smallest recommended. See previous page.
- **Rollers** - **NEVER** cut or slice directly on any of the roller surfaces as any resultant damage is not covered by the warranty. **ALWAYS** use cutters with enclosed blades to prevent cutting rollers and to avoid expensive replacement costs.
- **Do not** feed objects such as staples, paper clips and rough or abrasive materials through the laminating rollers. Keep all objects such as tools, rulers, pens, markers, etc. away from the roller opening. Refrain from leaving such items on the front table to prevent them accidentally being fed into the rollers.
- **The rubber covering** of the top pull roller is very soft. **Do not scratch** its surface with a sharp object or a fingernail.
- **Servicing and Replacement Parts** - Refer all servicing to your distributor. Servicing by any unauthorized technician voids the warranty.

WARNING: When the laminator is not in use, always ensure that the top roller has been raised to prevent flat spots from developing. Flat spots will effect the quality of the output and is not covered by the warranty.

Technical Specification

	42 ^{plus}	62 ^{plus}
Maximum working width	1133 mm (44,5 in)	1615 mm (63.6 in)
Maximum heated width	1110 mm (42 in)	1575 mm (62 in)
Maximum speed	1,8 m/min (6 ft/min)	
Maximum main roller temperature	120°C (250°F)	
Maximum roller opening	29 mm (1 1/8 in)	
Maximum substrate thickness	25.4 mm (1 in)	
Roller construction	Steel with high-release silicone covering	
Shaft capacities (core inner diameter)	76.2 mm (3 in)	
Maximum material diameter	210 mm (8 1/4 in)	
Dimensions	Width	1720 mm (68 in) 2200 mm (87 in)
	Height	1220 mm (47.3 in)
	Depth	762 mm (30 in) including tables
Net weight	440 kg (968 lbs)	523 kg (1153 lbs)
Shipping weight	480 kg (1056 lbs)	573 kg (1263 lbs)
Power supply - 3 phase*	3N/PE 200-230 ±10% VAC 50/60 Hz, 13 A	3N/PE 200-230 ±10% VAC 50/60 Hz, 16 A
Power supply - 1 phase (USA only)	200-230 ±10% VAC 50/60 Hz, 26 A	200-230 ±10% VAC 50/60 Hz, 35 A
Maximum power consumption	5500 Watts	8000 W

* Although 3 phase supply is used, it is not a true 3 phase machine. The three phases are used independently.

The information contained herein is general and does not constitute any warranties or guaranties.

Identification

The machine has an identification plate. On the Image 42^{plus}/62^{plus} it is located on the rear of the right cabinet.

Operating Conditions

Temperature

10°C ~ 50°C (50°F ~ 122°F)

Do not expose the laminator to direct sunlight as output quality may be affected.

Moisture

30% ~ 95% non-condensing

Ideal humidity ~ 55%

Dust

Avoid a dusty environment because the films used on this laminator may attract dust and the output quality may be affected.

Uncrating and Moving The Image 42^{plus}/62^{plus}

Your IMAGE 42^{plus}/62^{plus} laminator is wrapped in plastic film to prevent moisture penetration. It is crated on an integral 4-way entry pallet including a cardboard folding box.

WARNING: When using a forklift, make sure that the length of the fork matches the size of the pallet. If necessary, use fork extensions.

NOTE: If future transportation of the laminator is a possibility, the pallet, crate and securing bolts should be kept in safe place.

To uncrate the laminator, please follow the instructions below:

Step 1 - Cut the straps that secure the cardboard box to the pallet.

Step 2 - Remove the box, and, using the provided 19 mm open-ended spanner, remove the four securing bolts, (located at the bottom of each cabinet) that hold the laminator to the pallet. Then use the provided 17 mm open-ended spanner to turn the four machine feet all the way down (clockwise direction) until the machine lifts a bit and the two wooden blocks can be removed. Next, turn the four machine feet **all the way up** (turning anti-clockwise). The machine is now standing on its four castors.

Step 3 - Remove the two ramps provided, and place them on the floor, against one of the short edges of the pallet.

Step 4 - WARNING: This step should only be carried out by two or more people. Do not attempt to do it on your own. Slowly roll the laminator down the ramp and onto the floor. Carefully push the laminator to its final location.

Step 5 - Using a spirit level, adjust the feet so that the machine is level from side to side (spirit level on front table) and front to back (spirit level on cabinet - check both sides).

Uncrating and Moving The Image 42^{plus}/62^{plus}

Step 6 - Cut the plastic straps (1) securing the two wooden blocks (2) between the rollers. Refer to the applicable paragraphs and connect the machine to the main electrical supply and set the main switch to ON. The upper roller will raise automatically to the max position. Remove the wooden blocks from the rollers.

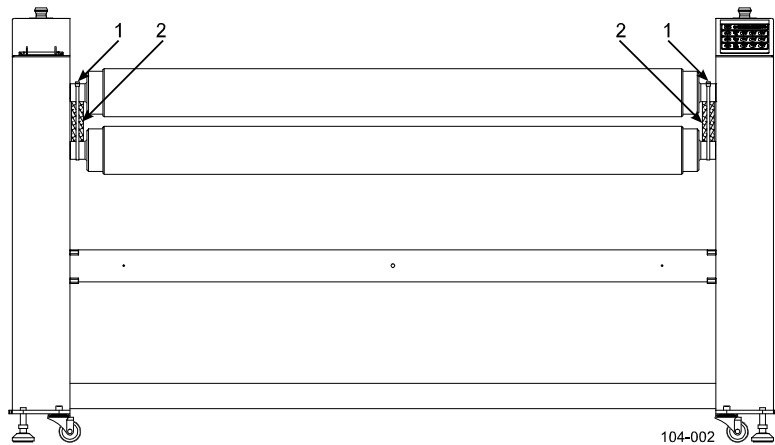

En

Wooden Blocks

Step 7 - Refer to the applicable instructions and, with the heaters set to off, operate the machine to turn the rollers until the wedges, situated between the pull rollers, are released.

Connection to the Electrical Supply

In process of setting up your **IMAGE 42^{plus}/62^{plus}**, the laminator will require connecting to the electrical supply. This should only be carried out by a qualified person.

NOTE: The machine is supplied with a 6 meter (20 feet) cable including a mains plug, in accordance with the identification plate. If this cable has to be shortened, or if the plug has to be changed, then the wire colors mean:

In case of single phase operation (i.e. US):-

Cable colors		US colors
Blue -	Neutral	White
Green/Yellow -	Earth	Green
Brown -	Live	Black

In case of a three phase machine (i.e. Europe):-

Blue -	Neutral
Green/Yellow -	Ground (Earth)
Brown -	Live phase 1
Black -	Live phase 2
Black -	Live phase 3

Should you have any questions regarding the installation of your **IMAGE 42^{plus}/62^{plus}**, please contact your local Distributor.

General Use

The IMAGE 42^{plus}/62^{plus}'s greatest quality is its simplicity. With it, a low-skilled operator is able to mount and laminate quickly, even continuously.

SAFETY IS IMPORTANT

DO NOT OPERATE YOUR LAMINATOR IN AREAS OF EXTREME HUMIDITY. KEEP HAIR, JEWELLERY AND LOOSE CLOTHING AWAY FROM THE LAMINATOR DURING OPERATION. ALWAYS TURN THE LAMINATOR OFF AND DISCONNECT FROM THE ELECTRICAL SUPPLY BEFORE OPENING THE SIDE CABINETS WHICH HOUSE THE INNER WORKINGS OF THE LAMINATOR.

En

Main Switch

The main ON/OFF switch is located on the right side of the machine.

The switch has two positions:

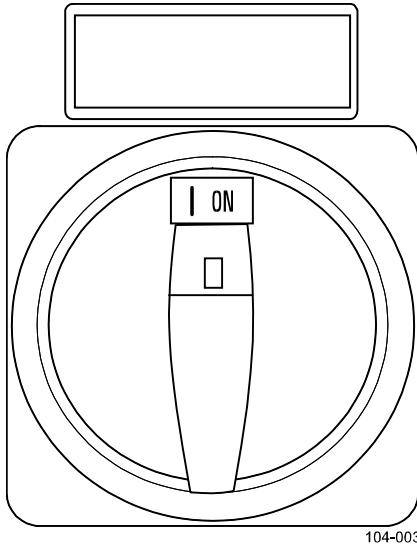

104-003

Supply voltage ON (I)

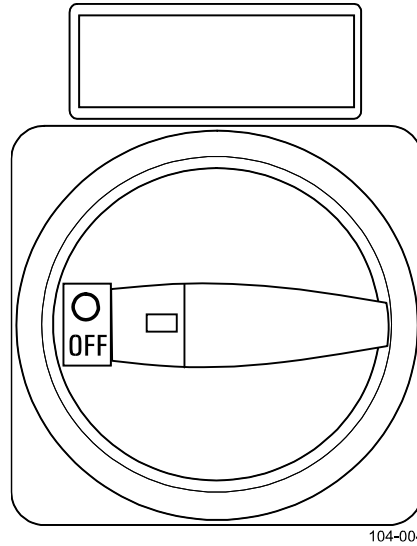

104-004

Supply voltage OFF (O)

The side cabinet, housing the electrical circuits, cannot be removed unless this switch is in the OFF position.

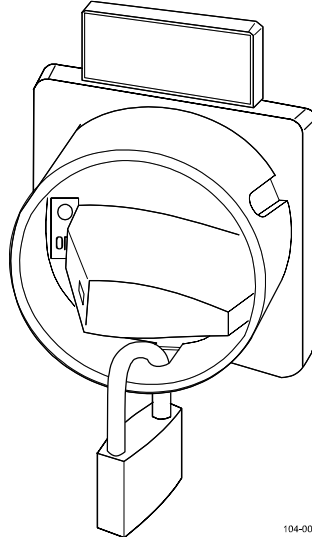

104-005

Switch secured in OFF (O) position

The switch can be secured in the OFF position to prevent unauthorized use.

Control Panel

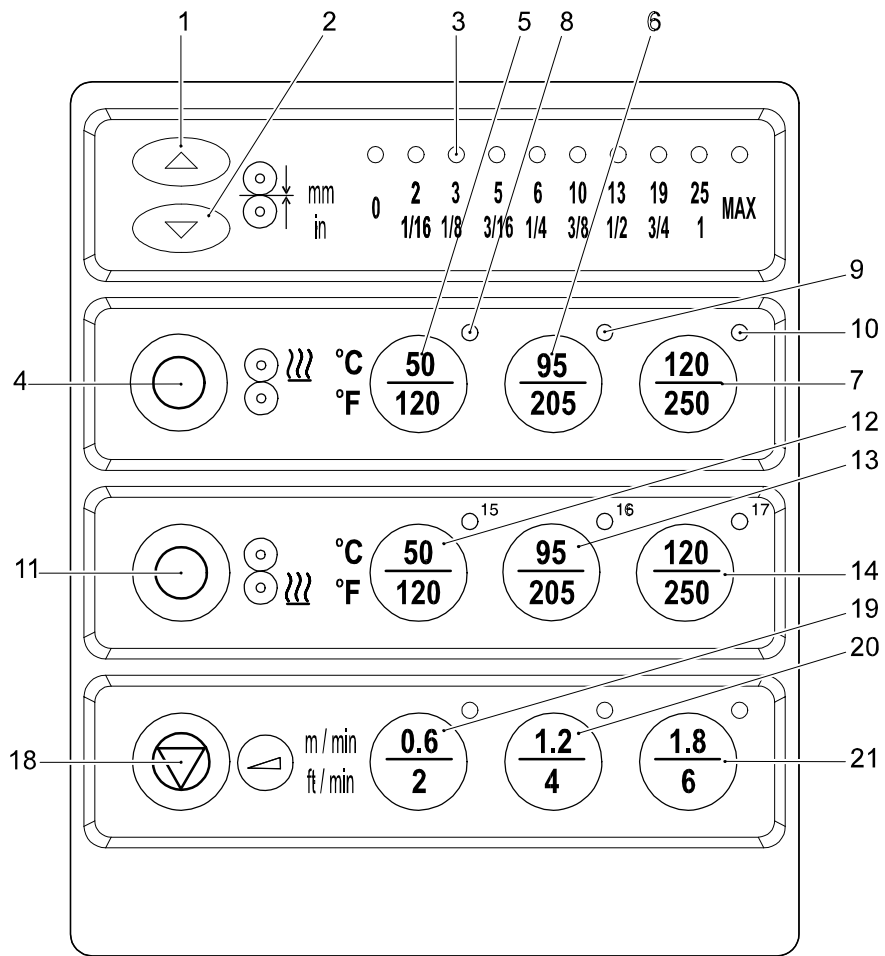

Control Panel

104-006

Nip setting system

1. Roller up button
2. Roller down button
3. Nip setting LED indicators

Top Heater

4. Heater OFF button
5. 50°C setting button
6. 95°C setting button
7. 120°C setting button
8. thru 10. LED indicators

Bottom Heater

11. Heater OFF button
12. 50°C setting button
13. 95°C setting button
14. 120°C setting button
- 15 thru 17. LED indicators

Motor control system

18. Motor stop button
19. 0.6 m/min button
20. 1.2 m/min button
21. 1.8 m/min button
22. thru 24. LED indicators



110°C setting: press 95°+120° at the same time!

En

Control Panel

The laminator's control panel is situated on the front right. The functions of the touch sensitive control panel are divided into 4 sections as follows:-

ROLLER NIP SETTING

This section controls the vertical movement of the top main roller and also controls the nip setting when mounting onto substrates.

- NOTE:**
- Before switching off the machine, check that the upper roller is fully raised (MAX position), to prevent a flat spot being induced into the rubber coating.
 - With a 0 mm nip opening, the top roller will automatically move to the 19 mm opening when the machine has not been used for 5 minutes.
 - If the nip opening is 2 mm or more and both heaters are switched off, or if only the top heater is set to 50°C, the top roller will automatically move to the 19 mm opening when the machine has not been used for 30 minutes.
 - If the nip opening is 2 mm or more and if heaters are switched on (except for only the top heater set to 50°C), the top roller will automatically move to the 19mm opening when the machine has not been used for 5 minutes.
 - If the nip opening is already 19 or 25 mm in the above situations, the top roller is raised to the maximum opening.
 - The upper roller will move automatically from the MAX position to its previous setting if the foot switch or one of the three speed buttons is pressed. This will prevent images/boards from being fed in when the rollers are open.

Pressing an up or down button will change the nip setting. Keep the button pressed until the flashing LED points to the desired value. When the upper roller reaches the actual setting, the LED will become steady. Any new setting will overwrite the previous internal setting.

Pressing the up and down buttons simultaneously will cause the upper roller to open to MAX from whatever nip setting is currently selected.

Pressing the two buttons again simultaneously will cause the roller to go back to its previous setting.

The up or down movement of the upper roller can be interrupted by any new nip setting, or by pressing the up and down buttons simultaneously.

Important:

- the nip setting can not be changed to a smaller value if a substrate is already placed between the rollers (the nip setting mechanism can not 'crush' a substrate, and therefore it is not able to find its new value). In this case, the upper roller will automatically move back to the MAX position to make it possible to remove the substrate.
- the nip setting system only functions if:
 - the machine is not running
 - the emergency stops are not activated
 - the infeed table is in its normal position
- the machine can only run if a nip setting has been completed (when the according LED becomes steady).

Control Panel

- if the upper roller is moving downward (during a nip setting) then the upper roller will reverse its movement (goes to MAX opening) when the photoelectric eyes are interrupted at that moment.

HEATER CONTROL

These sections control the temperature of the top and bottom rollers. Whilst warming the laminator up, it is advisable to close the rollers and switch the motor on. From cold, the laminator takes approximately 25 minutes to reach 120°C (250°F). The heaters maintain the selected temperature to within $\pm 4^{\circ}\text{C}$ ($\pm 7.2^{\circ}\text{F}$) across the entire roll face.

To prevent accidental changing of the heater settings, each button has to be pressed for 2 seconds before the change takes place.

During heating up, the relevant LED indicator will flash slowly. Once the temperature setting is reached the LED will become steady.

Should an over-temperature situation occur, then the LED will flash at a fast rate.

En



The cooling fans will operate **ONLY** when the top roller or bottom roller temperature setting is 95°C, 110°C or 120°C. If you do not want the cooling fans to operate, press the chosen speed setting button again.

It is quite normal that, during and after the process, the temperature LEDs occasionally flash. The temperature controller will maintain the roller temperature within the temperature bandwidth.

MOTOR CONTROL

This section controls the laminators motor speed. The figures quoted are liner speeds through the rollers.

Slow-mode

The machine has a so-called slow-mode, which can be activated by pressing the foot switch. To maintain slow-mode, keep the foot switch pressed.



Once the machine is running in slow-mode, interrupting the photoelectric eyes does NOT stop the machine; an audible beep will be heard, and the roller speed will be 0.6 m/min only. Releasing the foot switch will stop the machine.



Changing from slow-mode to normal running mode without stopping (to prevent stop marks on the substrate):

- during slow-mode (keep the foot switch pressed), press one of the preset speed buttons, but do not release the foot switch yet
- next, release the foot switch
- finally release the speed button.

Control Panel



Changing from normal running mode to slow-mode without stopping:

- press the foot switch

NOTE: Releasing the foot switch will stop the machine.



Reversing the machine

To reverse the rotation direction of the rollers, press both 0.6 and 1.2 speed buttons simultaneously. As long as the buttons are pressed, the machine will run in reverse direction, at a speed of 0.6 m/min only. Releasing the buttons will stop the machine.



Care must be taken not to get loose clothing, long hair, jewellery and fingers pinched in the rear face of the pull rollers and main rollers.



The rotation of the rollers will stop when:

- The photoelectric eyes in front of the main rollers are interrupted

NOTE: This does NOT happen when the foot switch is used (slow-mode).

- An emergency stop button is pressed
- The foot switch is pressed for a short moment
- The input table is lifted
- Excessive unwind tensions are set (the motor will be shut off electronically, press the stop button on the control panel to reset).
- The stop button on the control panel is pressed
- Both 0.6 and 1.2 speed buttons are pressed simultaneously (to reverse the rotation direction of the rollers).

Emergency Stop Buttons

There are two buttons and they are located on the top of the left and right cabinets of the machine. They shut down the rotation and movement of the rollers and should only be used in the case of an emergency. Once pressed these buttons lock, and they must be rotated to be reset before the machine can be used again. After being reset, the rollers will move to their upper position. See also Safety Information section.

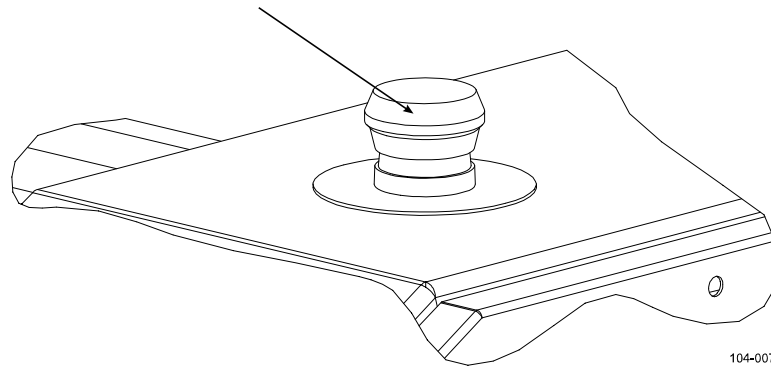

Emergency Stop button

104-007

En

Loading Rolls

How to load the laminator:

Step 1 - From the rear of the laminator, load the required rolls onto the top and bottom unwind positions ensuring that the rubber blocking cords are on the top and bottom of the shaft. Release the unwind tension if necessary, to turn the shaft to the correct position.



NOTE: The adhesive side of the film should be facing you.

Step 2 - Centre the rolls in relation to each other by measuring from core of the roll to the side panel of the laminator. Both rolls should have the same distance.

WARNING: Do not overload the unwind shafts while loading/unloading.

Webbing

Specific webbing instructions for various applications are covered later in the manual, however, one of the most critical aspects to achieving good results is the process of webbing. Mastering webbing is the key to operating the laminator effectively.

During webbing, the in-feed table must be swung into the up position when webbing the lower film, and down when webbing the upper film.

NOTE: If the in-feed table is swung up from the working position the drive motor will stop, (or not start) until the table is repositioned.

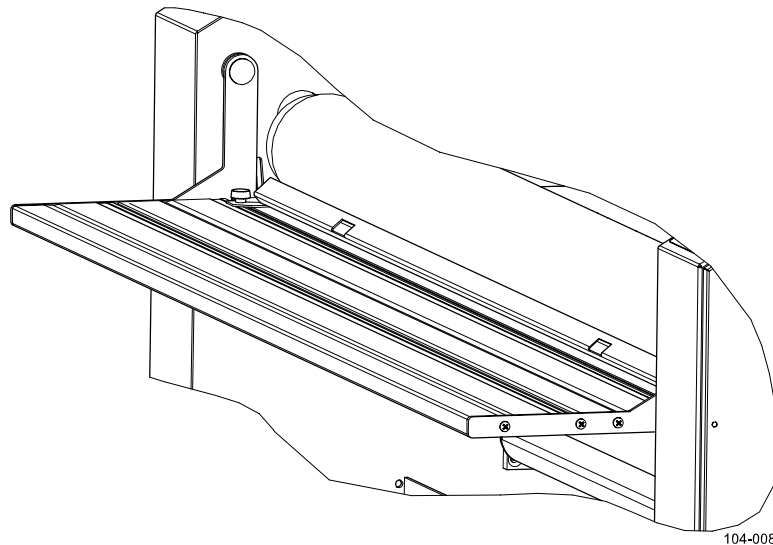

In-feed Table

Unwind Brakes

The smooth flow of the laminating film is affected greatly by the unwind brakes. These are located on the right hand side of the machine.

How to set the brakes:

Turning the knob clockwise increases the film unwind tension; turning the knob counter-clockwise decreases the tension.

NOTE: In general, no or light unwind tension will be required.

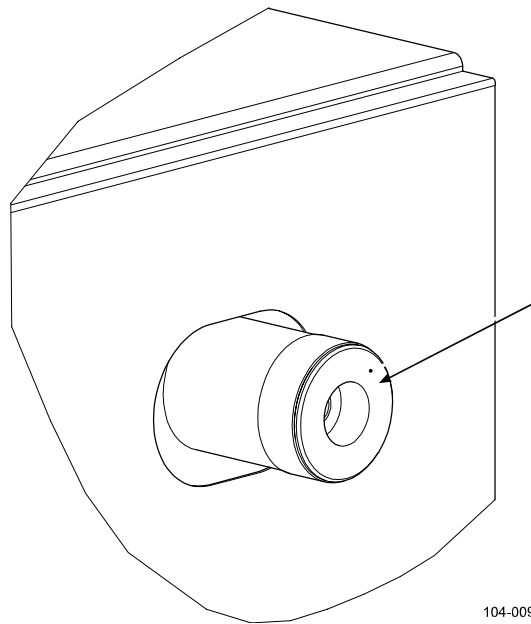

Unwind Brake

En

Roller Nip Settings

Whenever you mount onto a board, etc., it is important to adjust the rollers to create a gap nearly equal to the thickness of the board being used. This is done so that anything passing between the rollers will receive the right amount of pressure and prevent damage to the rollers rubber surface (and possibly the board).

How to set the nip:

Step 1 - Determine the thickness of the board that you will use for mounting.

Step 2 - Adjust the nip setting by pressing either ▲▼ buttons on the control panel to the same thickness as preciously measured.

NOTE: For non-standard substrate thickness, select the next lowest nip setting i.e. 8 mm board - select 6 mm (1/4") nip.



NOTE: Pressing the up/down buttons at the same time at any nip setting will send the top roller to the max. position. Pressing these buttons again will bring the top roller down to its previous set nip.

Equivalent Measurements

Metric (mm)	Inches	Decimal
2	1/16	0.0625
3	1/8	0.125
5	3/16	0.1825
6	1/4	0.25
10	3/8	0.375
13	1/2	0.5
19	3/4	0.75
25	1	1.000

Cooling Fans

The laminator is equipped with a bank of cooling fans that are used during encapsulation. The fans are positioned at an angle to the web.



The cooling fans will operate **ONLY** when the top roller or bottom roller temperature setting is 95°C, 110°C or 120°C. If you do not want the cooling fans to operate, press the chosen speed setting button again.

Feeding Images

To aid feeding images, the laminator is equipped with an “Image Guide”. This device is bolted to the feed-in table in front of the main rollers and it prevents the images from lifting away from the table during feeding, or from interrupting the photoelectric eyes.

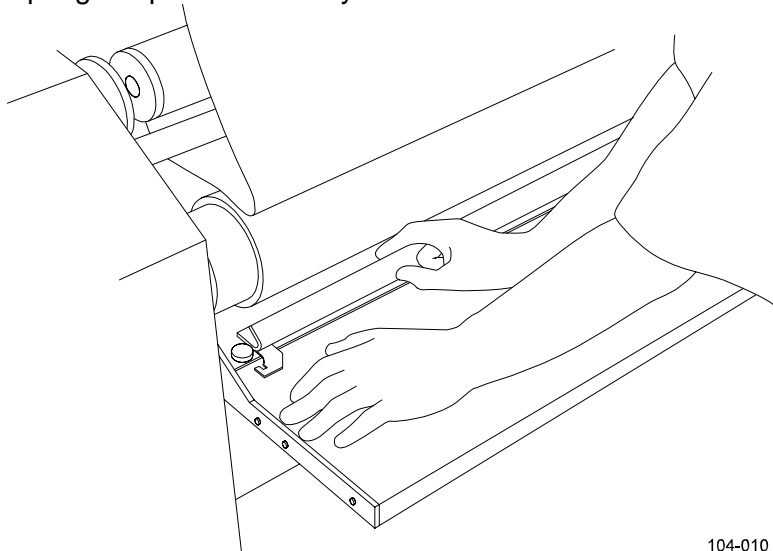

En

104-010

Mounting / Dismounting Image Guide

How to feed images:

Step 1 - For good results, the process requires that the images be fed through correctly. The leading edge of each image must be flat all the way across or any wrinkles or creases in the image will show when encapsulated - perhaps even magnified. To aid feeding, the leading edge should also be straight.

Step 2 - Feed the image into the machine ensuring that the edge is parallel to the roller. To help this, the edge of the image can be seen through the two windows in the “image guide”, which is in front of the rollers.

NOTE: Do not stop the motor whilst an image is being finished as this can cause marks in the output.

Laminating and Adhesive Coating (Decaling)

This process involves sandwiching an image between either a hot or cold laminate on the face of the image and a pressure-sensitive adhesive on the rear. This process can be used to create self adhesive images for mounting down onto various substrates.

Once the machine reaches the operating temperature, the laminator may be stopped, the top roller raised and webbed as per the following diagrams. Refer to the Temperature/Speed chart at the back of this manual for settings and recommended film combinations

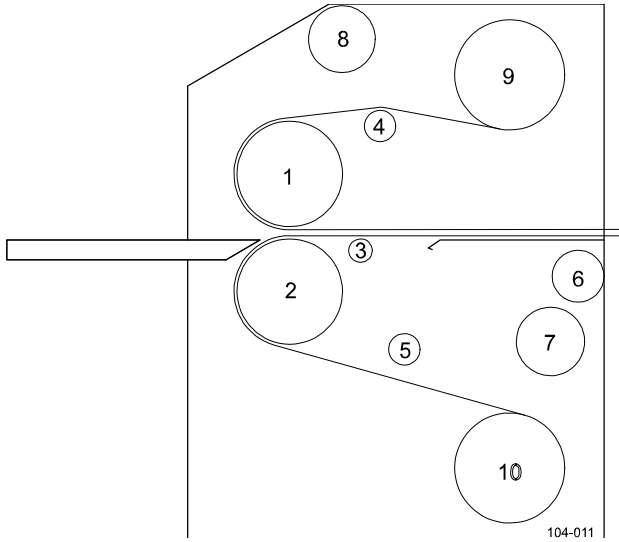

- 1. Heated top roller
- 2. Heated bottom roller
- 3 thru 5. Idlers
- 6. Top pull roller
- 7. Bottom pull roller
- 8. Wind-up shaft
- 9. Upper supply roll
- 10. Lower supply roll.

Decaling (with liner)

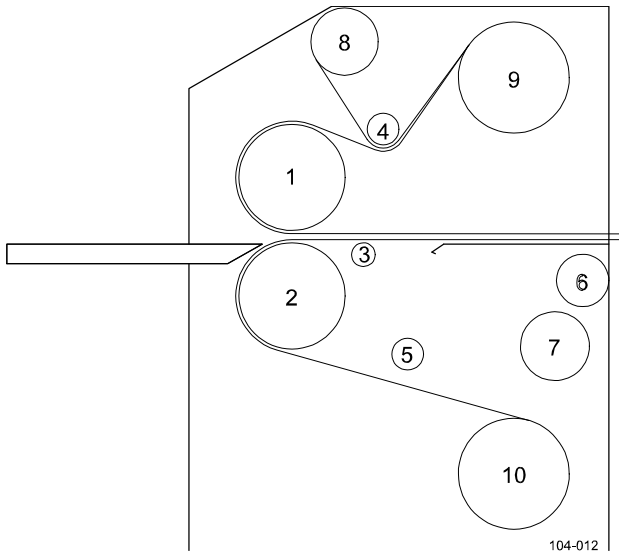

- 1. Heated top roller
- 2. Heated bottom roller
- 3 thru 5. Idlers
- 6. Top pull roller
- 7. Bottom pull roller
- 8. Wind-up shaft
- 9. Upper supply roll
- 10. Lower supply roll.

Decaling (without liner)

Laminating and Adhesive Coating (Decaling)

Preparation:

Select the films that you will use on the top and bottom of the images, it is advisable to use slightly wider width films compared to the print width. This way the print can be trimmed with a border, so as to reduce waste, but be enough to leave a border. Mount rolls onto the unwind shafts with the adhesive facing you. Web as follows:

Step 1a - Linerless films - pull the film down from the top unwind station and thread under the idler bar (unless pressure sensitive is used, then thread above idler). Pull the film evenly over the top roller and across the face of the rollers.

Step 1b - Lined films - pull the film down from the top unwind station and thread under the idler bar. Connect the film and liner to the take up station with a piece of tape. The take-up station should have a scrap core placed over it to allow easy removal of the scrap liner. Split the film from the release liner and pull the film evenly across the face of the rollers.

En

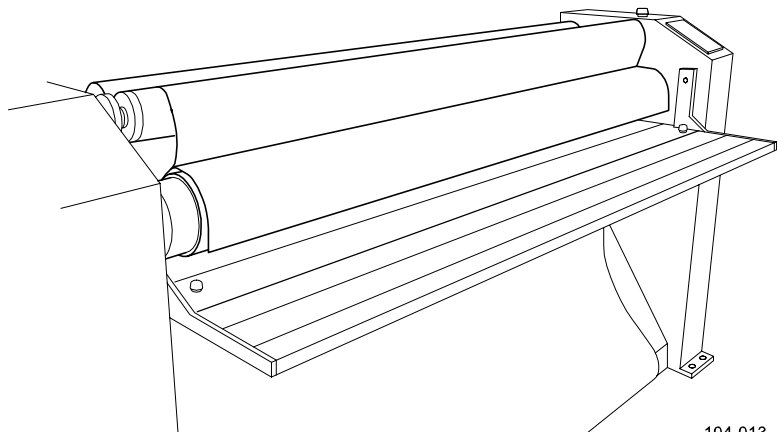

104-013

Webbing film (film + liner)

Step 2 - Remove image guard and swing the table into the upper position.



NOTE: Check if the film widths of the upper and lower web are the same!
NEVER use the pull rollers when decaling!

Laminating and Adhesive Coating (Decaling)

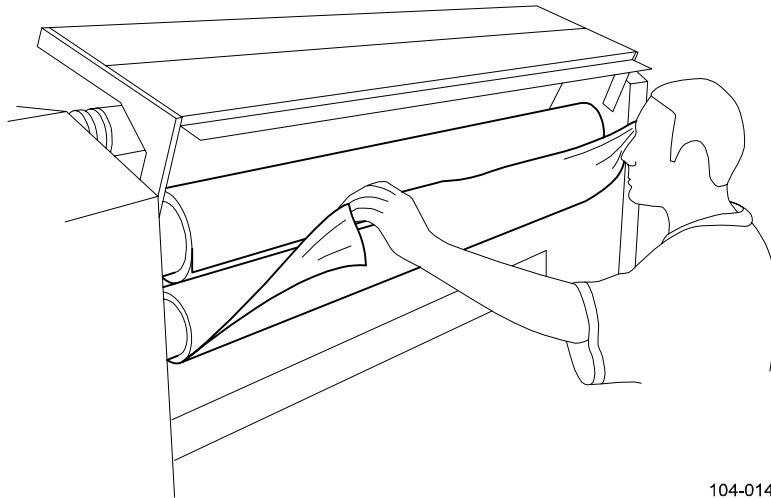

104-014

Placing the lower film across the roller faces.

Step 3 - Pull the pressure-sensitive adhesive up from the bottom unwind station, across the face of the bottom roller, and place evenly across the top roller. The films will then heat and stick together.

Step 4 - Lower the feed table into the operating position.

Step 5 - Close the rollers, depress the foot switch and then using a piece of card as a leader, push the films into the nip of the rollers. Using the foot switch, advance the leader between the rollers until the end of it reaches the rear fan bank. Release the foot pedal.

Step 6 - From the front of the laminator run the film and adjust the brake tension on the unwind station until any wrinkles or creases in the films over the face of the rollers are reduced to a minimum. They should clear within approximately 1m (3-4 feet). If the wrinkles persist, cut the film and web the laminator again.

Step 7 - Locate the image guard on the feed table.

YOU ARE NOW READY TO FEED IMAGES.

Mounting

This process involves mounting down previously made decals onto a substrate. No films or adhesives are used in this process.

To mount decals onto a substrate

Step 1 - Place the mounting board on a flat surface. Lay your image face down on the mounting board and expose approximately 25 mm (1") of the adhesive by peeling back the release paper along one of the edges. Fold the release paper back making an even crease.

Step 2 - Turn the image over and carefully position the exposed adhesive edge of the image squarely onto the board.

Step 3 - Once positioned correctly, press the image firmly down onto the exposed adhesive from the centre toward the edges to ensure smooth surface. This is the edge that will be fed into the rollers first.

Step 4 - Ensure that the nip setting of the rollers corresponds to the board thickness.

Step 5 - Push the edge of the board into the rollers and depress the foot switch until the board and image are just caught by the nip.

Step 6 - Flip the in-tacked portion of the image over the top roller with one hand so that the release paper can be peeled off the image with the other hand. Depress the foot switch to feed the board through the rollers. At this point, continuous run can be selected by pressing one of the speed settings.

NOTE: Take care that the liner is not grabbed by the rollers.

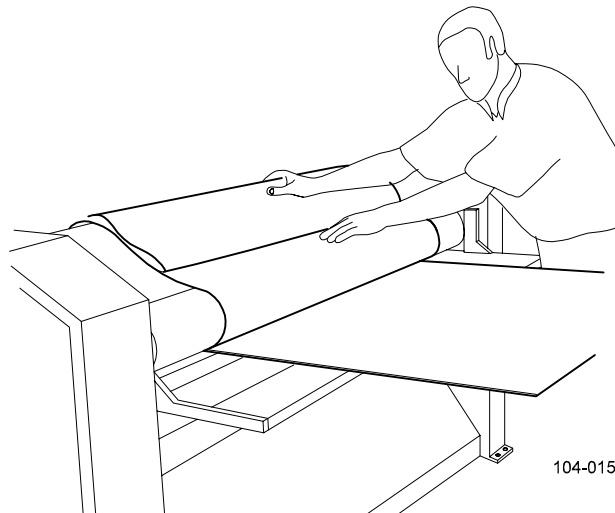

104-015

Mounting Decals

Mounting

Step 7 - When the end of the board is near the nip, you may want to slow the machine down. To do this, just press the foot switch to enter slow mode. Releasing the foot switch will stop the machine.

Step 8 - Remove the mounted image from the rear of the laminator and trim it if necessary.

If the board is accidentally sent in too far at first, the release liner will get caught and will be impossible to pull back. In this case, stop and reverse the motor until the liner can be pulled away. The image must be held against the roller while the board feeds through to prevent wrinkles. As the process becomes more familiar, the speed of the laminator may be increased to make the process more efficient.



Take care that the optical safety system is not tripped by the release liner.

NOTE: Only hard boards (PVC, Polystyrene, MDF, hard board, etc.) that are of the same thickness as the nip settings should be used, otherwise damage to the rollers can occur.

Encapsulating

This process involves completely sealing an image between two heat activated films.

Once the machine reaches the operating temperature, the laminator may be stopped, the top roller raised and webbed as per the following photographs and diagrams, Refer to the Temperature/Speed chart at the back of this manual for settings and recommended film combinations.

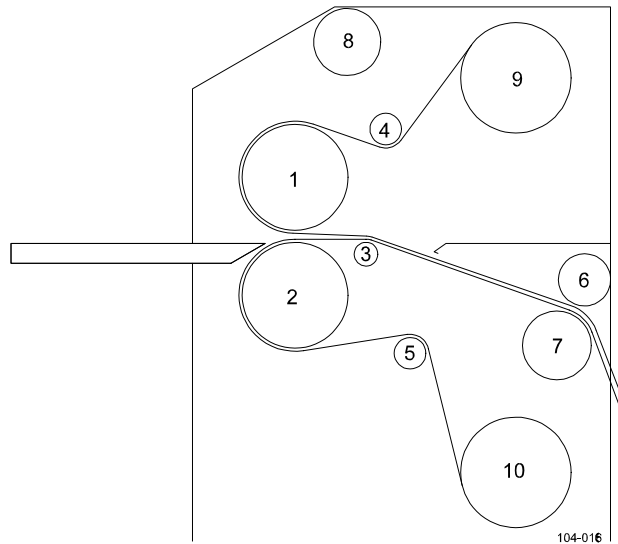

1. Heated top roller
2. Heated bottom roller
- 3 thru 5. Idlers
6. Top pull roller
7. Bottom pull roller
8. Wind-up shaft
9. Upper supply roll
10. Lower supply roll.

En

Encapsulating



Preparation:

NOTE: Check if the film widths of the lower and upper web are the same!

It is advisable to use slightly wider films compared to the print width. This way the print can be trimmed with a border and not too much film waste is generated, Mount rolls onto the unwind shafts with adhesive facing you. Web as follows:

Step 1a - Linerless films - pull the film down from the top unwind station and thread under the idler bar, (unless pressure-sensitive adhesive is used, then thread above idler). Pull the film evenly over the top roller and across the face of the rollers.

Encapsulating

Step 1b - Lined films - pull the film down from the top unwind station and thread under the idler bar. Connect the film and liner to the take-up station with a piece of tape. The take-up station should have a scrap core placed over it to allow easy removal of the scrap liner. Split the film from the release liner and pull the film evenly across the face of the rollers.

Step 2 - Remove image guard and swing the table into the upper position.

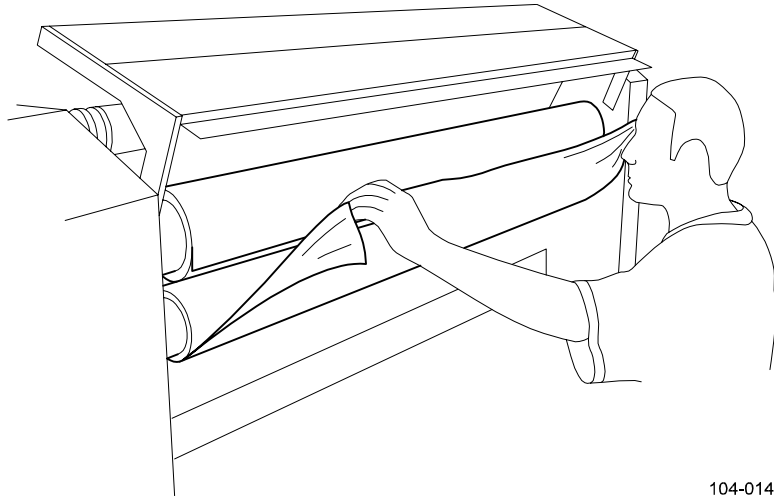

104-014

Placing the lower film across the roller faces

Step 3 - Pull the film up from the bottom unwind station, thread it around the idler bar and up and over the face of the top and bottom laminating rollers. The films will then heat and stick together.

Step 4 - Lower the feed table into the operating position, and close the rollers.



NOTE: Keep the film under tension (turning the top unwind manually) to prevent the photoelectric eyes being tripped when the upper roller is moving down.

Step 5 - Depress the foot switch and then using a piece of card as a leader board, push the films into the nip of the rollers. Using the foot switch, advance the leader between the rollers until the end of it reaches the rear fan bank. Release the foot pedal.

Encapsulating

NOTE: Use the 2 mm thick leader board supplied with the machine.

Step 6 - Moving to the rear of the laminator, with the film/board resting on the fan bank, cut off the leader leaving the film with a straight edge. Feed the film down into the pull rollers and use the foot switch to advance the film until it reaches about 15 cm (6") beyond the pull rollers and then stop the motor.

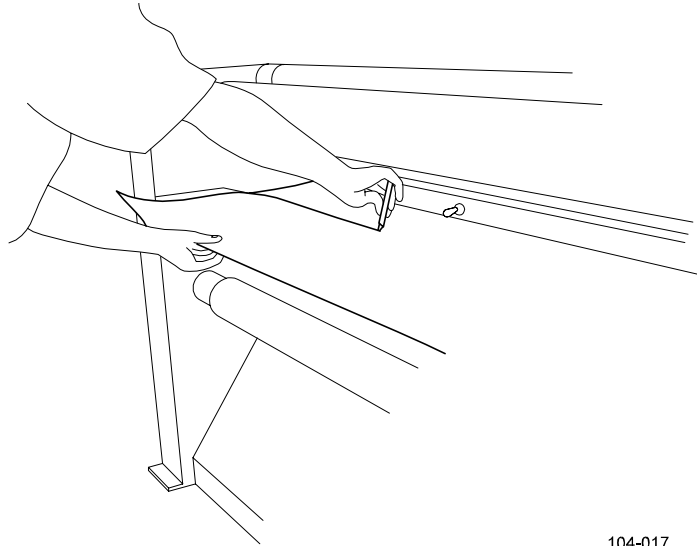

En

104-017

Cutting off the leader

Step 7 - From the front of the laminator run the film until the output is wrinkle free. Best results will be obtained when the film unwind tension is zero or very light.

Wrinkles, visible on the roller face do not show on the output.

Step 8 - Refit the image guard on the in-feed table.

YOU ARE NOW READY TO FEED IMAGES.

Pre-Coating

This process is used to coat substrates with a self adhesive coating onto which images can be mounted. The same process is used to create a carrier board (sled).

Preparation:

Mount the roll of self wound pressure sensitive adhesive on the top unwind of the laminator with the exposed adhesive facing you. Have a leader board ready with the same thickness as the boards to be coated.

Step 1 - Pull the adhesive down from the top unwind station and over the top roller evenly, and down across the face of both main rollers. Lift the in-feed table for a moment to do this.

Step 2 - Measure the thickness of the board(s) to be coated, and select the correct nip setting.

Step 3 - Press the foot switch and, using the leader board, push the adhesive into the roller nip. Release the foot switch when the rear edge of the leader board is almost leaving the roller nip.

Step 4 - Position the board to be coated into the nip, and choose one of the three speed settings.



NOTE: Do not wait for more than 5 minutes before starting the machine, otherwise the upper roller will raise automatically.

When coating boards, ensure that the next board to be coated follows the previous board without any gaps.

Step 5 - Follow the last board being coated with the leader board once again to allow the final board to clear the laminating rollers and then stop the motor and raise the top roller.

Temperature and Speed Settings

Key: 95°C off 1.2
 Top Roller Temperature in Centigrade
 Bottom Roller Temperature in Centigrade
 Process Speed in Meters per Minute

Mounting, Pre-Coating and Laminating

Top Roller / Process	Print Mount Plus	Print Shield Std Matte	Print Shield Std Gloss	Print Shield Std Lustre	Jet Guard Crystal Gloss	Jet Guard Crystal Matte	Jet Guard Deep Crystal	Jet Guard Gloss 3 mil	Jet Guard Gloss 5 mil
Board Coating	50°C off 1.8								
Single Side Laminating		50°C off 1.8	50° off 1.8	50°C off 1.8	95°C off 1.2	95°C off 1.2	95°C off 1.2	95°C off 1.2	110°C off 1.2

En

Encapsulation & Decaling

Top Roller / Bottom Roller	Print Shield Std Matte	Print Shield Std Gloss	Print Shield Std Lustre	Jet Guard Gloss 75	Jet Guard Gloss 125	Jet Guard Crystal matte	Jet Guard Deep Crystal	Thermashield Matte/Lustre 75	Thermashield Gloss 75	Thermashield Gloss 125	Thermashield Gloss 250	Floortex
Print Mount Plus	50°C 50°C 1.8	50°C 50°C 1.8	50°C 50°C 1.8	95°C 50°C 1.2	95°C 50°C 1.2	95°C 50°C 1.2	95°C 50°C 1.2	110°C 50°C 1.2	110°C 50°C 1.2	110°C 50°C 1.2	-	-
Jet Guard Gloss 75	-	-	-	95°C 95°C 1.2	95°C 95°C 1.2	95°C 85°C 1.2	95°C 85°C 1.2	-	-	-	-	-
Jet Guard Gloss 125	-	-	-	95°C 95°C 1.2	95°C 95°C 1.2	95°C 95°C 1.2	95°C 95°C 1.2	-	-	-	-	-
Jet Guard Crystal Matte	-	-	-	85°C 95°C 1.2	95°C 95°C 1.2	95°C 95°C 1.2	95°C 95°C 1.2	-	-	-	-	-
Thermashield Gloss 75	-	-	-	-	-	-	-	110°C 110°C 1.2	110°C 110°C 1.2	110°C 110°C 1.2	-	-
Thermashield Gloss 125	-	-	-	-	-	95°C 110°C 1.2	95°C 110°C 1.2	110°C 110°C 1.2	110°C 110°C 1.2	110°C 110°C 1.2	-	-
Thermashield Gloss 250	-	-	-	-	-	95°C 110°C 0.6	95°C 110°C 0.6	-	-	-	110°C 110°C 0.6	-
Stoplight 220	-	-	-	-	-	95°C 110°C 1.8	95°C 110°C 1.8	-	-	-	-	50°C 110°C 1.2
Stoplight 370	-	-	-	-	-	95°C 110°C 1.2	95°C 110°C 1.2	-	-	-	-	50°C 110°C 1.2

104-022

Cleaning & Maintenance

Cleaning



Do not use an abrasive cleaner on any surface. It may damage the surface of the silicone surface of the rollers or the paint work. Only use a damp cloth. Do not let water get onto the panels of the laminator as they are not sealed. Water may enter the electrical circuits and cause injury to persons or damage to the equipment when power is applied.

1. External Surfaces

Clean the external surfaces of the laminator with a damp cloth. If necessary, use household detergent to remove difficult stains.

2. Cleaning

Use an Image Roller Cleaner to remove excess adhesive. This should be done with the rollers hot. When cleaning the top roller, place a scrap piece of board under the top roller to reduce waste adhesive falling onto bottom roller.

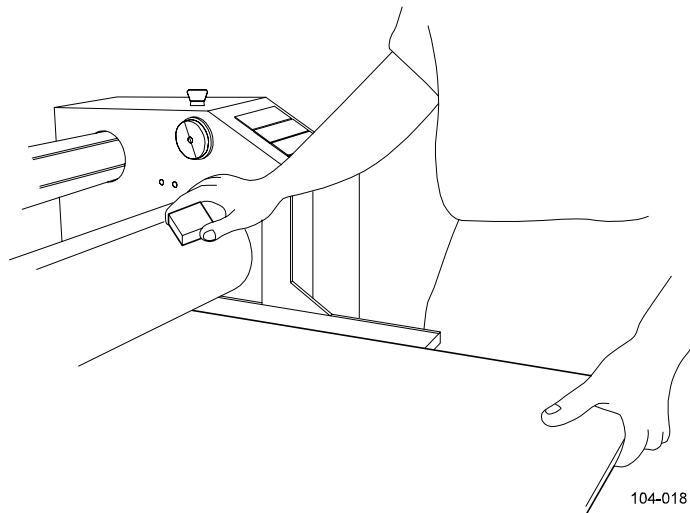

104-018

Cleaning the Upper Roller

Cleaning & Maintenance

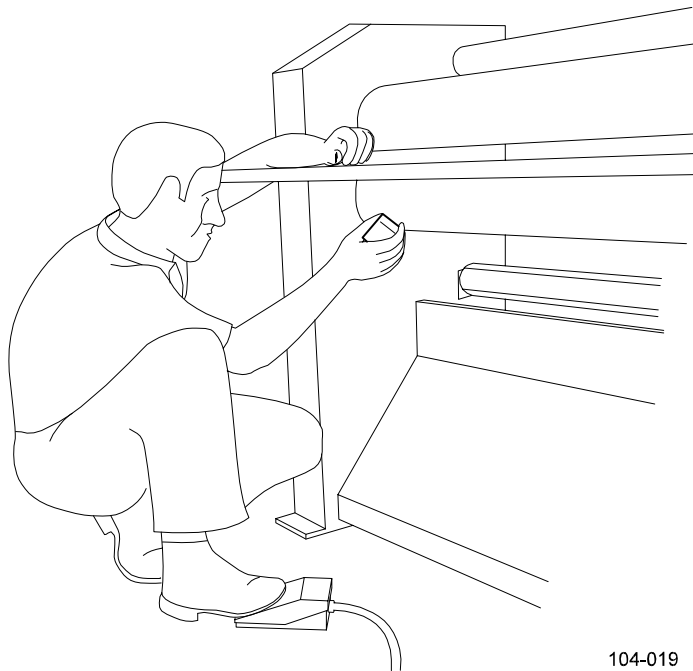

104-019

En

Cleaning the Lower Roller

For more thorough cleaning allow rollers to cool and then use isopropyl alcohol. This is best done using a clean, lint free cloth. Do not spill IsoPropylAlcohol (IPA) on the laminator.



When using IPA, the rollers must be cold. IPA is inflammable. The flash point of IPA (isopropanol) is 11°C (51.8°F). The self-ignition temperature is 400°C (752°F).

NOTE: The rollers should be cleaned every day or the adhesive will build up and may eventually damage the rollers.

To clean the pull rollers use a clean, lint-free cloth moistened with water and household detergent.

Maintenance

The Image 42^{plus}/62^{plus} requires little maintenance, only the following are necessary:-

1. Wipe the in-feed table with a dry cloth as necessary.
2. Clean the rubber blocking cords on the unwind shafts as necessary.
If a rubber blocking cord on the unwind shaft becomes too slack after a longer period of time, unscrew one of the clamps, cut off 1 cm (0.5") of the cord, and fasten it again using the clamp.

For technical assistance, please contact your distributor.

Troubleshooting

Problem: The machine has no display

- **Solution 1:** Unplug the machine. Check the fuses on the main control board situated in the right cabinet. This should only be done by authorized safety or maintenance personnel. Spare fuses are located on the upper horizontal cable channel.
- **Solution 2:** Ensure that the mains supply to the laminator is O.K.

Problem: The machine will not run.

- **Solution 1:** Ensure that the emergency stop buttons have not been activated - rotate to reset.
- **Solution 2:** Make sure the photo safety eyes are not blocked.
- **Solution 3:** Make sure the in-feed table is in the down position.
- **Solution 4:** With the laminator unplugged, check the fuses inside the right cabinet. This should only be done by authorized safety or maintenance personnel.

Problem: The machine is not heating up.

- **Solution 1:** Make sure that the heater(s) are switched on (LED illuminated on control panel).
- **Solution 2:** Check the circuit breaker for the machine. This should only be done by authorized safety or maintenance personnel.

Problem: The top roller is not descending

- **Solution 1:** The in-feed table should be in the down position.
- **Solution 2:** Release the emergency stops.
- **Solution 3:** Something is tripping the safety eyes.

Problem: The top roller is not ascending

- **Solution 1:** Release the emergency stop.
- **Solution 2:** The in-feed table should be in the down position.

Glossary of Laminating Terms

Encapsulating - Sandwiching an image between two heat activated films.

Film - A synonym for laminate. The clear material used in the laminating and encapsulating processes.

In-feed - The side of the machine from which images are fed.

Mounting - Affixing permanently an image onto some kind of backing board.

Nip - The spot where the top and bottom rollers meet.

Out-feed - The side of the laminator from which completed images emerge.

Release Liner - The backing on a pressure-sensitive, heat-activated laminate or mounting adhesive. Once the release liner is peeled off, the adhesive layer becomes exposed.

Decal - An image that has been laminated on top and has an adhesive backing.

Leader Board - A piece of stiff card or foam board used to lead film, etc. into the nip of the laminating rollers. Also used when pre-coating to prevent adhesive getting onto the rollers.

Carrier Board (Sled) - A board that has a non-stick surface that is used when laminating one side of an image only. These are sometimes made using a flat board coated with a self-wound, pressure-sensitive adhesive. The silicone release liner is not removed during coating and provides the necessary non-stick surface).

Pre-coating - The process of coating a substrate with an adhesive mounting film onto which an image can be mounted.

En

Accessories

The following accessories are supplied with the machine:

User manual
Quick reference guide
Safety knife
Rubber cleaning block
Tape measure
Spare fuses (inside right-hand cabinet)
Open-ended spanner set
17 mm open-ended spanner
10 mm Allen key
Empty film core
Leader board
Board-guide incl. fasteners.

Addresses

For more information about SEAL Graphics products, contact please contact your nearest sales office.

SEAL Graphics Americas
7091 Troy Hill Drive
Elkridge
MD 21075
U.S.A.
Tel: (410) 379 5400
Tel: (410) 379 8960

SEAL Graphics UK Ltd
1 Watkins Close,
Burnt Mills Industrial Estate
Basildon, Essex SS13 1BJ
United Kingdom
Tel: +44 (0) 1268 530 331
Fax: +44 (0) 1268 725 864

SEAL Graphics Europe BV
Kanaaldijk O.Z. 3
P.O. Box 29
8100 AA Raalte
The Netherlands
Tel: +31 (0) 572 345 500
Fax: +31 (0) 572 345 501

SEAL Graphics Canada
1601 Matheson Blvd. E. Unit # 4
Mississauga, Ontario,
Canada
L4W 1H9
Tel: +1 905 212 9232 / 866 212 7325
Fax: +1 905 212 9313

SEAL Graphics Pacific Limited
Unit A, 13th Floor, Block 1
Leader Industrial Centre
Tsuen Wan, New Territories,
Hong Kong.
Tel: +852 2407 3738
Fax: +852 2408 0973