

44/62 Ultra

Laminator

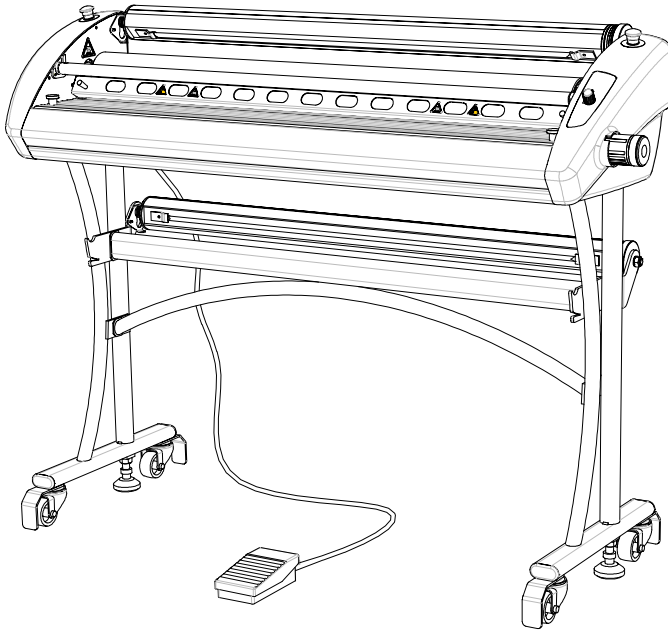

User manual
Manuel de l'utilisateur
Betriebsanleitung
Manual de uso
Manuale d'uso

SEAL®

English

All rights reserved

All information included in this manual as well as information included in supplements or addendum to this manual is subject to copyright law. This information shall not be used, copied, reproduced, transmitted or disclosed to third parties without our prior written consent.

SEAL Graphics assumes no responsibility for any errors that may appear in this document nor does it make expressed or implied warranty of any kind with regard to this material, including, but not limited to, the implied warranties of merchantability and fitness for a particular purpose.

Seal Graphics shall not be liable for incidental or consequential damages in connection with, or arising out of the furnishing, performance, or use of this document and the program material which it describes.

Français

Tous droits réservés.

Toutes les informations contenues dans ce manuel ainsi que celles des suppléments ou ajouts à ce manuel sont soumis aux lois sur le copyright. Ces informations ne doivent pas être utilisées, copiées, reproduites, transmises ou divulguées à des tiers dans notre autorisation préalable par écrit.

SEAL Graphics n'accepte aucune responsabilité pour toute erreur pouvant apparaître dans ce document et ne donne aucune garantie tacite ou expresse eu égard à ce matériel, y compris mais sans s'y limiter, à toute garantie tacite de qualité marchande ou d'adaptabilité à un usage particulier.

SEAL Graphics n'est pas responsable des dommages accessoires ou indirectes liés à ou découlant de la diffusion, performance ou l'utilisation de ce document et du matériel décrit.

Deutsch

Alle Rechte vorbehalten.

Alle Informationen in diesem Handbuch sowie Informationen in Ergänzungen oder Zusätzen zu diesem Handbuch unterliegen dem Urheberrechtsgesetz. Die Informationen dürfen ohne unsere Genehmigung nicht verwendet, kopiert, wiedergegeben, übertragen oder an Dritte weitergegeben werden.

SEAL Graphics haftet nicht für Fehler, die in diesem Dokument auftreten können, noch übernimmt SEAL Graphics Europe BV keinerlei ausdrückliche oder implizite Garantie in Bezug auf dieses Material, einschließlich, jedoch nicht begrenzt auf die implizierte Garantie der Marktgängigkeit und Eignung für einen bestimmten Zweck.

SEAL Graphics haftet nicht für auftretende oder Folgeschäden in Verbindung mit oder entstehend aus der Ausstattung, Leistung oder Benutzung dieses Dokuments und des Programmmaterials, das es beschreibt.

Español

Reservados todos los derechos.

Toda la información incluida en este manual y en los suplementos a anexos de este manual están sujetas a las leyes de derechos de autor. Queda prohibida la utilización, copia, reproducción, transmisión o divulgación de esta información a terceros sin nuestro consentimiento previo por escrito.

SEAL Graphics no se hace responsable de los errores que pudieran aparecer en este documento ni tampoco ofrece garantía implícita o explícita de ningún tipo en relación con el material descrito, incluyendo, aunque sin que ello constituya un límite, las garantías implícitas de comercialización e idoneidad para una finalidad concreta.

SEAL Graphics no responderá de los daños imprevistos o emergentes relacionados con, o que puedan surgir del suministro, funcionamiento o el uso de este documento y del material de programa que describe.

Italiano

Tutti i diritti riservati.

Tutte le informazioni di questo manuale, nonché quelle dei supplementi o integrazioni a questo manuale sono soggette ai diritti d'autore (copyright) Queste informazioni non possono essere usate, copiate, riprodotte, trasmesse o comunicate a terze parti senza il nostro previo consenso scritto.

SEAL Graphics Europa BV non si assume alcuna responsabilità per eventuali errori che possono comparire nel presente documento, né offre garanzia esplicita o implicita di alcun tipo in relazione a detto materiale, comprese, ma non limitatamente a, garanzie implicite di commerciabilità e adeguatezza per un particolare scopo.

SEAL Graphics Europa BV non sarà responsabile per danni accidentali o indiretti relativi a, o derivanti dalla fornitura, dalle prestazioni, o dall'utilizzo del documento e dal materiale relativo al programma descritti.

Seal Graphics Europe,
P.O.Box 29,
8100AA Raalte,
the Netherlands,
Tel.: 0031 572 345 500
Fax: 0031 572 345 501

44/62 Ultra

Laminator

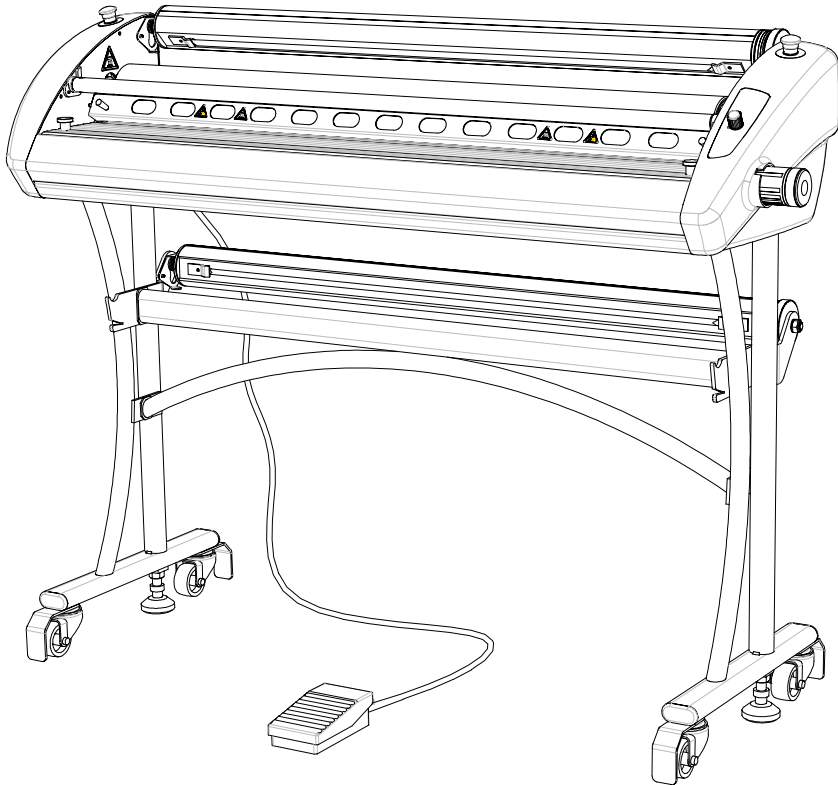

English

Français

Deutsch

Español

Italiano

User manual

UM103EN, Rev.3.1

Feb.2005

INTRODUCTION

We would like to thank you for purchasing a Seal 44/62 Ultra, designed to give you many years of reliable service. By following the guidelines outlined in this manual for proper care and use, you can depend on many years of trouble-free profitability from your investment. Your 44/62 Ultra laminator meets the CE Machinery Safety Directive (89/392/EEC, including 91/368/EEC, 93/44/EEC and 93/68/EEC) and is cETL listed (UL 1950/EN60950).

Statement of intended use.

The 44/62 Ultra laminator has been designed to be used with Seal materials. When used with this products, you are able to mount, mount and laminate, and encapsulate prints in one step. Your machine has not been tested with any other materials and is not recommend for use with products other than Seal supplies.



WARNING:

THIS MACHINE IS DESIGNED FOR MOUNTING AND LAMINATING. ANY USE OTHER THAN THE INTENDED MAY CAUSE DAMAGE TO THE MACHINE OR PHYSICAL HARM TO THE USER.

Liability Statement

The details given in this manual are based on the most recent information available to us. They may be subject to change in the future. We retain the right to make changes to the construction or the design of our products without accepting any responsibility for modifying earlier versions previously delivered.

Standardised Symbols



Passages marked this way offer an idea / tip or other information on the efficient use of this unit.



WARNING:

PLEASE PAY ATTENTION TO ALL PASSAGES MARKED THIS WAY. THIS INFORMATION IS VITAL TO PREVENTING USER INJURY AND / OR DAMAGE TO THE UNIT. FAILURE TO FOLLOW THIS INFORMATION COULD VOID THE USER'S WARRANTIES AND TRANSFER ALL SAFETY OBLIGATIONS TO THE USER.

TABLE OF CONTENTS

Introduction	2
Table of Contents	3
1 Specifications	5
1.1 Technical Specifications	5
1.2 Electrical specifications	6
1.2.1 US versions	6
1.2.2 EU versions	6
2 Safety / Important Safeguards	7
2.1 Safety symbols used on the equipment.	7
2.2 Emergency stop-buttons	7
3 Unpacking and Installation	8
3.1 Ambient Conditions	8
3.2 Surroundings	8
3.3 Power supply	8
3.4 Workspace Requirements	8
3.5 Setting up the laminator in 4 steps.	9
3.5.1 Adjustable feet	11
4 Unit description	12
4.1 Control panel	13
4.2 Motor control	13
4.2.1 Slow-mode	14
4.2.2 Reversing the machine	14
4.3 Unwind brakes	15
4.4 Roller nip settings	15
4.5 Image guide and wind-up idler storage place.	15
5 Process Control Sheet	16

6	Application Processes	17
6.1	Loading the machine	17
6.1.1	Loading film onto the unwind shaft	17
6.1.2	Loading the unwind shaft into the machine	17
6.2	Webbing the films	18
6.2.1	Using film with release liner.	19
6.3	Feeding images	20
6.3.1	How to feed images:	20
6.4	Laminating and adhesive coating (Decaling)	21
6.5	Decaling without liner	22
6.6	Mounting	23
6.6.1	To mount decals onto a substrate	23
6.7	Encapsulating	24
6.8	Pre-Coating	25
6.9	Mounting using a ProSEAL® Mounting Board	25
6.10	Mounting and Lamination using a ProSEAL® pouch Board.	26
6.11	Encapsulating with a ProSEAL® Flexible Pouch using a ProSEAL® Carrier Board	27
7	Maintenance & Cleaning	28
8	Troubleshooting	29
9	Glossary of Terms	30
10	Limited Warranty	31
11	Index	32

1 SPECIFICATIONS

1.1 Technical Specifications

		U.S.	Metric conversions	
Max. Working Width	processes up to 50°C	44 ultra	44" maximum	1118 mm max.
		62 Ultra	62" maximum	1574 mm max.
	processes up to 125°C	44 ultra	42" maximum	1067 mm max.
		62 Ultra	60" maximum	1523 mm max.
Max. Speed		4.92 ft/min.	1.5 m/min.	
Temperature settings		Off (ambient temp.)	Off (ambient temp.)	
		125°F, 195°F, 250°F	50°C, 90°C, 120°C	
Dimensions (HxWxD)	44 Ultra	43.7"x58.3"x22"	1110x1480x560 mm	
	62 Ultra	43.7"x76.3"x22"	1110x1940x560 mm	
Shipping dimensions (HxWxD)	44 Ultra	28.4"x63"x24.8"	720x1600x630 mm	
	62 Ultra	28.4"x81"x24.8"	720x2060x630 mm	
Weight				
	Net Weight	44 Ultra	222 lbs	101 kg
		62 Ultra	297 lbs	140 kg
Shipping Weight	44 Ultra	331 lbs	135 kg	
	62 Ultra	416 lbs	189 kg	
Maximum roll diameter	Top unwind	6.3"	160 mm	
	Bottom unwind	8"	200 mm	
	Release liner wind-up	5"	125 mm	
		3"	76.2 mm	
Core size				
Maximum Board Thickness		0.393" (3/8")	10 mm	
Roller Opening (Nip) settings		0, 1/16", 1/8", 3/16", 1/4", 5/16", 3/8"	0, 2, 3, 5, 6, 8, 10mm	
Roller Pressure	44 Ultra	5.54 lbf/in	0.97 N/mm.	
	62 Ultra	4.43 lbf/in	0.78 N/mm	
Roller Construction		Two siliconized steel rollers.		

Keep the area around your laminator clear with adequate space around it so you can feed, receive and trim mounted and / or laminated images.

1.2 Electrical specifications

Push the power button (at least 1 sec.) and the forward (or reverse) button on the control panel, to run the laminator.

The electrical specifications of the machines are:

1.2.1 US versions

44 Ultra	1N/PE 110VAC +/-10%, 50/60Hz, 16A
62 Ultra	1N/PE 230VAC +/-10%, 50/60Hz, 13A

For the US version, the applicable wall outlet (**receptacle**) is, shown below.

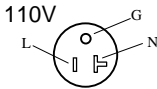

NEMA 5-20R
Using 20 Amp Breaker
Note: T-slot is not applicable for
Canada

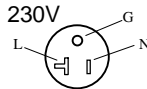

NEMA 6-20R
Using 20 Amp Breaker
Note: T-slot is not applicable for
Canada

1.2.2 EU versions

44 Ultra	1N/PE 230VAC +/-10%, 50/60Hz, 9A
62 Ultra	1N/PE 230VAC +/-10%, 50/60Hz, 13A

For the EU versions, in the UK, the following is applicable:



BS 1363 – 13A
wall receptacle:
Use the provided
BS 1363 plug

For the EU versions, mainland Europe, the following is applicable:



France
Belgium



Germany, The Netherlands
Portugal, Spain

Use the provided Schuko plug.

2 SAFETY / IMPORTANT SAFEGUARDS

2.1 Safety symbols used on the equipment.



ROTATING PARTS

MECHANICAL HAZARD. FAILURE TO USE CAUTION NEAR EXPOSED ROLLERS COULD RESULT IN PHYSICAL INJURY. BE CAREFUL THAT ITEMS SUCH AS LOOSE CLOTHING, LONG HAIR AND JEWELRY DO NOT BECOME ENTANGLED IN ROTATING PARTS.



HOT OBJECTS

FIRE HAZARD. THE LAMINATOR CONTAINS A HEATED TOP ROLLER WHICH MAY REACH TEMPERATURES OF 135°C (275°F). THERE IS A DANGER OF SEVERE BURNS IF THE HEATED TOP ROLLER IS TOUCHED DURING USE.

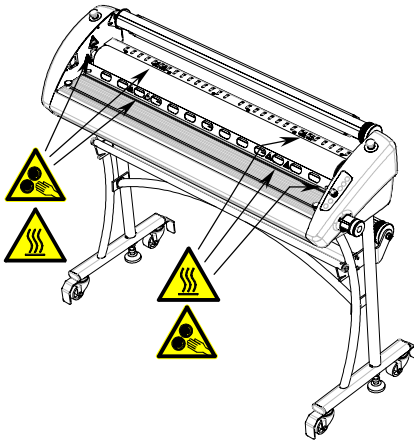

Figure 1

2.2 Emergency stop-buttons

There are two buttons; they are located on the top of the left and right plastic covers of the machine.

The Emergency-stop buttons shut down the rotation of the rollers and should only be used in case of an emergency. Once pressed, these buttons lock, and they must be rotated to be reset before the machine can be used again.

3 UNPACKING AND INSTALLATION

Please read and fully understand the entire manual before proceeding to use your laminator.

3.1 Ambient Conditions

The following environmental conditions are ideal for the best operation of the laminator.

Ambient Temperature

The best temperature for the 44/62 Ultra is between 16°C and 35°C (50°F and 95°F). Do not expose the laminator to direct sunlight as output quality may be affected.

Relative humidity

For best results, the ambient relative humidity for the 44/62 Ultra should lie between 70% and 90%.

Water and moisture

If the laminator is installed in a damp room or near water, the electrical power supply must be in accordance with the standards prevailing in the country concerned.

3.2 Surroundings

Install the laminator in surroundings that are as clean and dust free as possible in order to obtain the highest quality end product. The materials that are used on this laminator can have an electrostatic charge and will attract dust, adversely affecting the output.

3.3 Power supply

Connect the machine in accordance with the details given on the identification plate attached to the rear of the machine. Refer also to the technical specifications in this section for more information.

3.4 Workspace Requirements

This unit should be situated away from heat sources such as heat registers or stoves.

The laminator's location or position should not interfere with its proper ventilation.

There should be enough space around the laminator to feed-in, exit, and trim mounted and/or laminated images.

The background dust level must not exceed that found in a typical office/computer room environment.

The work area should be level, flat, and well lit.

3.5 Setting up the laminator in 4 steps.

- Remove the cardboard box and the plastic bag as described on the outside of the box.
- Pick the box behind the laminator which contains the stand parts.
- Mount the LH-side part of the stand as shown in next figure. (The LH-part is recognizable by a spring utility on the bracket.)
- Use two serrated washers and two socket screws M6x16 (see fig.2)
Do not tighten the screw completely.

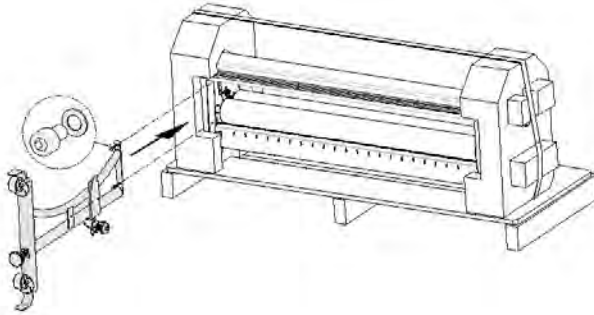

Figure 2

- Mount the RH-part of the stand onto the laminator as shown in figure 3. Use the serrated washers and the socket screws M6x16.
Do not tighten these screws completely.

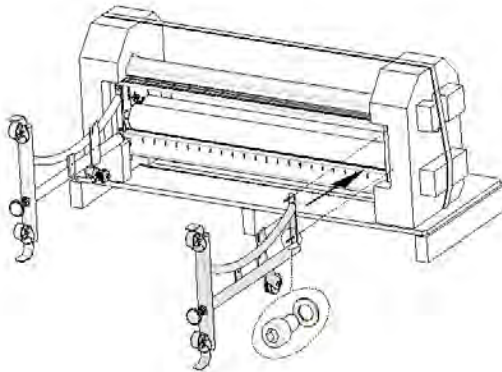

Figure 3

- Finally, mount the middle part between the LH- and RH parts.
- Use two serrated washers and two socket screws M6x16.
- Tighten now all screws which were used in previous steps.

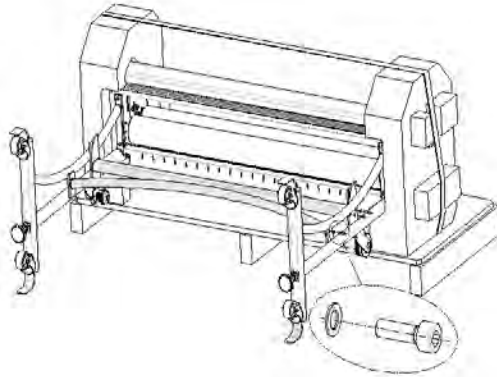

Figure 4

- Lift the laminator from the pallet and position it onto it's castors.
- Make sure that the stand legs do not slide away during lifting.
- Cut the strap and remove the protecting covers.

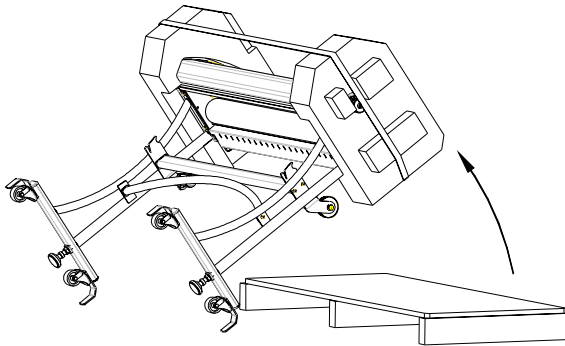

Figure 5

Your 44/62 Ultra must be setup at the place where it will be used. The stand must be placed on a flat level surface.

- Remove the tie-wraps by using a small flat-edged screwdriver to press the clip to release the tie and remove the blocks that hold the top roller.
- Inspect the machine for any physical damage.
- Plug the power cable into the grounded outlet with appropriate service.

The machine must be installed next to an outlet! Do not use extension cords. The plug and the outlet must be easily accessible. Please ensure that you plug your laminator into a grounded, three-prong outlet. Please ensure that the total load of the other items using the same circuit breaker do not exceed its breaking value.

The laminator should only be connected to a power supply outlet of the voltage and amperage marked on the rear panel. The laminator has a grounded plug (three prongs). To reduce the risk of electrical shock, this plug is intended to fit only a grounded outlet of the proper amperage, and in only one way.

3.5.1 Adjustable feet

To secure the stand on the floor, turn the adjustable foot down by hand, until it's pressed against the floor. Manually lock the adjustable foot with the nut (figure 6).

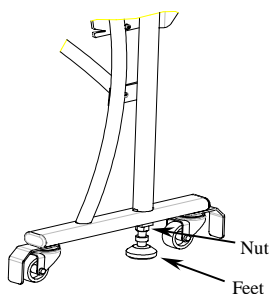

Figure 6

4 UNIT DESCRIPTION

Features and benefits of the 44/62 Ultra:

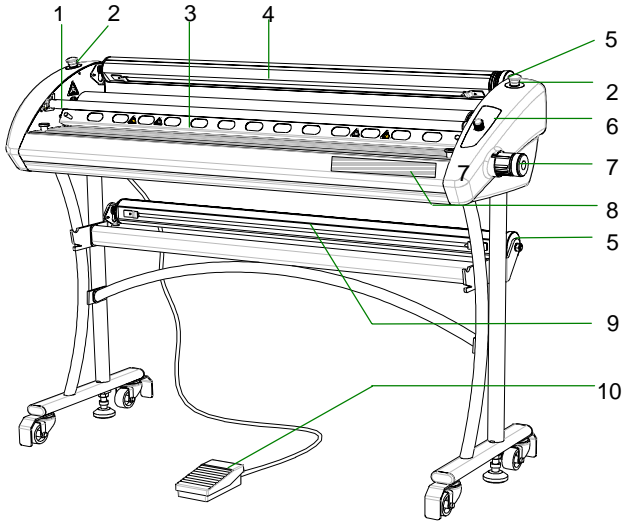

Figure 7

Identification of parts

- | | | |
|----|-----------------------|---|
| 1 | Wind-up idler | Idler (removable) to support the wind-up core for the release-liner |
| 2 | Emergency stop button | |
| 3 | Image guide | To help infeed images. It is removable when mounting. |
| 4 | Upper unwind shaft | The shaft is suitable for rolls having a 3-inch core |
| 5 | Unwind brake | A simple means of setting the unwind tension. |
| 6 | Control panel | Controls rotation of the rolls, temperature and standby. |
| 7 | Nip knob | To adjust the gap between the rollers |
| 8 | Process control sheet | Shows how to preset the machine. |
| 9 | Lower unwind shaft | The shaft is suitable for rolls wound onto a 3-inch ID core |
| 10 | Foot switch | To engage slow mode. |

The ID-label is located on the rear side of the machine.

4.1 Control panel

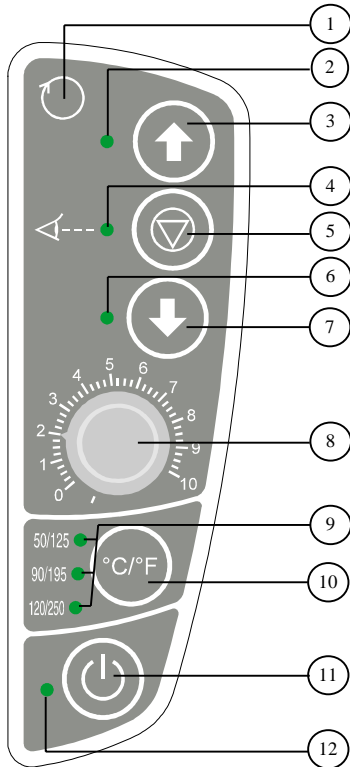

- | | | |
|----|----------------------------|--|
| 1 | Drive symbol area | |
| 2 | LED run forward | Lit when machine runs forward |
| 3 | Button run forward | Push button |
| 4 | LED optical safety system | Lit when light beam is not interrupted. |
| 5 | Stop button | Push button |
| 6 | LED run reverse | Lit when machine runs reverse |
| 7 | Button run reverse | Push button |
| 8 | Speed adjustment knob | Each number represents the amount of ½ feet/min. (15cm/min.) |
| 9 | LED temperature setting | |
| 10 | Temperature setting button | Toggle push button to preset the temperature. (press 2 seconds to switch the heating system off) |
| 11 | Power button | Toggle push-button (press 2 seconds) |
| 12 | Power LED | Lit when machine is switched on. |

Figure 8

4.2 Motor control

The speed of the rollers is continuously adjustable between 0 and 1.5 m/min. (0 and 4.8 ft/min.) Pressing the ↑ key runs the rollers in forward direction, pressing the ↓ key reverses the direction of the rollers. The stop key stops the roller movement.

4.2.1 Slow-mode

The machine has a so-called slow-mode, which can be activated by pressing the foot switch. To maintain slow-mode, keep the foot switch pressed.



WARNING:

ONCE THE MACHINE IS RUNNING IN SLOW-MODE, INTERRUPTING THE PHOTOELECTRIC EYES DOES NOT STOP THE MACHINE; AN AUDIBLE BEEP WILL BE HEARD, AND THE ROLLER SPEED WILL BE 0.6 M/MIN. ONLY. RELEASING THE FOOT SWITCH WILL STOP THE MACHINE.



Changing from slow-mode to normal running mode without stopping (to prevent stop marks on the substrate):

- During slow mode (keep the foot switch pressed), press the $\hat{\uparrow}$ (forward) button on the control panel. The machine will run at the pre-set speed.
- Next, release the foot switch.
- Finally release the $\hat{\uparrow}$ (forward) button.



Changing from normal mode to slow-mode without stopping:

- Press the foot switch
Note: Releasing the foot switch will stop the machine.

4.2.2 Reversing the machine

To reverse the rotation of the rollers, press the \Downarrow (reverse) button. As long as the button is pressed, the machine will run in reverse direction, at a speed of 0.6 m/min. only. Releasing the button will stop the machine.



WARNING:

CARE MUST BE TAKEN NOT TO HAVE LOOSE CLOTHING, LONG HAIR, JEWELLERY AND FINGERS PINCHED BETWEEN THE PULL ROLLERS AT THE REAR SIDE OF THE MACHINE.

The rotation of the rollers will stop when:

- The photoelectric eyes in front of the main rollers are interrupted
Note: This does NOT happen when the foot switch is used (slow-mode).
- An emergency stop button is pressed
- The foot switch is pressed for a short moment
- Excessive unwind tensions are set (the motor will be shut off electronically, press the stop button on the control panel to reset).
- The stop button on the control panel is pressed

4.3 Unwind brakes

Tighten the supply brake so that it applies sufficient tension to laminate. Turning the knurled collar in a clockwise direction increases the breaking tension applied on the laminate. Turning the collar counter-clockwise decreases the tension. The best setting for the brake tension is determined by the materials you are using and is learned through experience.

4.4 Roller nip settings

Whenever you mount onto a board, etc., it is important to adjust the rollers to create a gap nearly equal to the thickness of the board being used. This is done so that anything passing between the rollers will receive the right amount of pressure and prevent damage to the roller's rubber surface (and possibly the board).

How to set the nip:

Determine the thickness of the board that you will use for mounting.

Adjust the nip setting. Grasp the nip-knob with your right hand and push in approximately $\frac{1}{4}$ " (6mm) to the left. Once the knob has disengaged from the stop, it may be rotated forward or backward (clockwise or counter-clockwise, as viewed from the right hand side of the unit), until the desired value is opposite the window at the base of the knob. Releasing the knob so that it moves back to the right and clicks into place will set the rollers for use. The measurements on the knob correspond to the 'Pouch board' thickness. There is also a fully closed stop for film only applications.

Note:

For non-standard substrate thickness, select the next lowest nip-setting i.e.; 7mm board – select $\frac{1}{4}$ " (6mm) nip.

4.5 Image guide and wind-up idler storage place.

When not in use, the Image Guide and the wind-up idler can be stored in the stand.

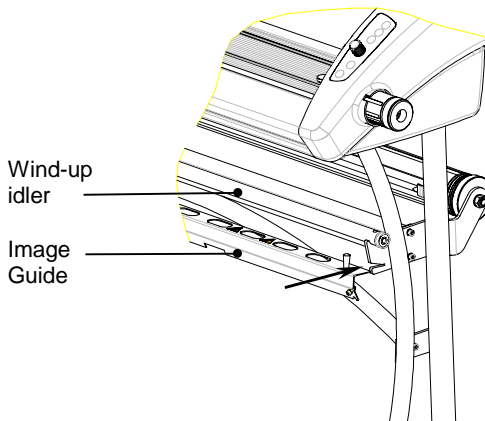

Figure 9

6 APPLICATION PROCESSES

6.1 Loading the machine

The following steps outline the basic procedure that have to be used for loading materials, webbing the laminator and setting the brake tension for the materials you will be using. To load and unload the material shafts, it is necessary to access the machine from the rear side.

Select the film(s) that you will use on the top (and bottom) of the images, it is advisable to use slightly wider width films compared to the print width. This way the print can be trimmed with a border, so as to reduce waste, but be enough to leave a border.

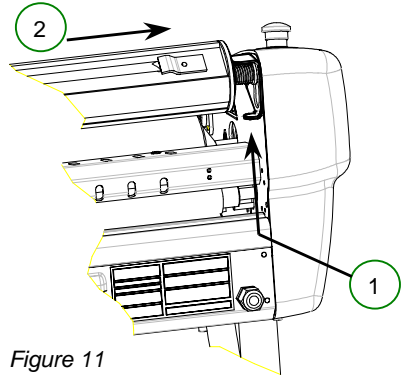

Figure 11

 **Always work in the centre of the machine.**

Check which temperature setting has to be used for your materials. (see figure 10)

6.1.1 Loading film onto the unwind shaft

- Remove the desired supply shaft (top or bottom) by pushing the interlock bracket (1) in the upper position and sliding the autogrip shaft (2) to the right against the spring pressure.
- Release the interlock bracket when the shaft is completely to the right.
- Lift the shaft out of the laminator.
- Slide the shaft into a material roll. Ensure that the rubber blocking cords are on the top and bottom of the shaft for easy loading.



CAUTION

Take care that the ends of the shaft do not become damaged during the loading and unloading.

6.1.2 Loading the unwind shaft into the machine

- Place the shaft, including the material, into the laminator by inserting it onto the left-hand supply shaft holder.
- Push the interlock bracket (see figure 11) upward with your finger before sliding the autogrip shaft further.
- Press against the spring pressure, until you can place the other end of the shaft onto the RH holder and onto the left-hand side holder.
- Center the material roll in the laminator.
- Rotate the unwind shaft until it locks into the unwind brake.

6.2 Webbing the films

After the laminator has heated up;

- Remove the infeed table and the wind-up idler. If applicable, the infeed table can be stored temporarily at the front tie-bar.
- Unroll the film on the top supply shaft, so that an adequate length is hanging over the top roller (see figures 12 & 13). If necessary, release the supply shaft brake.

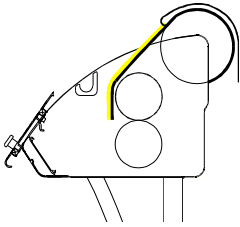

Figure 12

With release liner

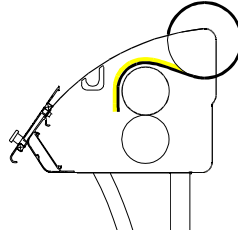

Figure 13

No release liner

- When using a laminate on the bottom, repeat the above procedure for the bottom supply-shaft.

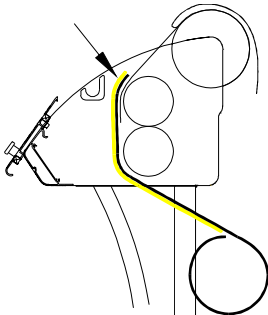

Figure 14

Webbing the bottom film

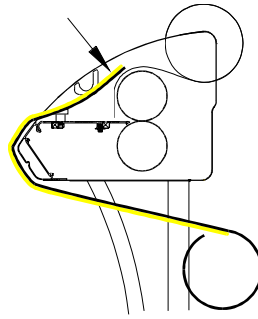

Figure 15

Alternative way for webbing HAS adhesive on the bottom unwind

- Stick the lower web on the upper web (figure 14 or 15)

- Use the provided leaderboard to push the film(s) through the nip (figure 16).

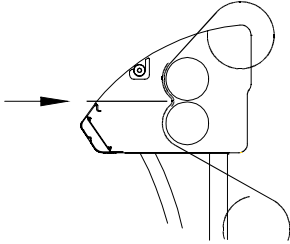

Figure 16

Refer to the following sections for specific webbing diagrams based on the process you are performing. Replace the infeed table.

6.2.1 Using film with release liner.

If you use a film with a liner on the upper unwind, then use a scrap core and the wind-up idler to wind-up the release liner.

Procedure:

- Push the film(s) just into the nip using the provided leader board, (see figure 16)
- Place the wind-up idler in its position.
- Flip the peeled liner back, let it hang over the idler.
- Place the scrap core on the idler and the top roller
- Attach the liner onto the scrap core, a piece of tape can help, but is not absolutely necessary.
- Push the films all the way through the machine, using the leader board.
- Start the machine at a low speed to ease this process.

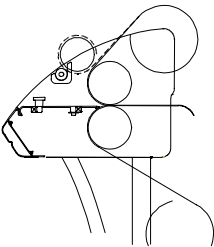

Figure 17

The top roller will drive the core, including the liner.

Always install the image guide.

6.3 Feeding images

To aid feeding images, the laminator is provided with an “Image Guide”. This device can be positioned in front of the top roller and it prevents the images from interrupting the photoelectric eyes. When changing the roller nip, the Image Guide moves together with the top roller.

To position the Image Guide, place it on the brackets, as shown in figure 18 and align the slots with the screwhead and push it completely towards the top roller.

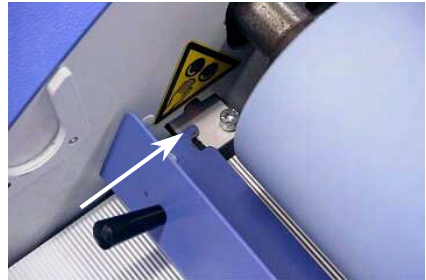

Figure 18

6.3.1 How to feed images:

For good results, the process requires that the images be fed through correctly. The leading edge of each image must be flat all the way across or any wrinkles or creases in the image will show when encapsulated - perhaps even magnified. To aid feeding, the leading edge should also be straight.

Feed the image into the machine ensuring that the edge is parallel to the roller. To help this, the edge of the image can be seen through the windows in the “image guide”, which is in front of the rollers.

Note:

Do not stop the motor whilst an image is being finished as this can cause marks in the output.

6.4 Laminating and adhesive coating (Decaling)

This process involves sandwiching an image between either a hot or cold laminate on the face of the image and a pressure-sensitive adhesive on the rear. This process can be used to create self-adhesive images for mounting down onto various substrates.

Once the machine reaches the operating temperature, the top roller may be raised and webbed as per the following diagrams. Refer to the Temperature/Speed chart on the front side of the machine and in the manual for settings and recommended film combinations

Decal process with liner;

Over-laminate on top and Pressure-sensitive mounting on bottom.

Linered films:

1. Pull the film down from the top unwind position.
2. Split the film from the release liner, flip the liner back (fig.19) and pull the film evenly across the face of the rollers.
3. Place the wind-up idler into the brackets.
4. Place the scrape core on the idler and the top roller.
5. Attach the liner onto the scrape core, using a piece of tape.
6. Push the films all the way through the machine, using the leaderboard.
7. Replace the infeed table.
8. **ALWAYS INSTALL THE IMAGE GUIDE.**

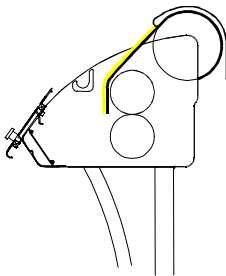

Figure 19

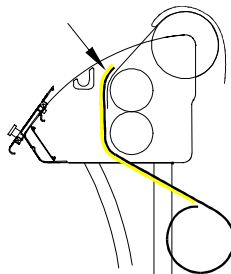

Figure 20

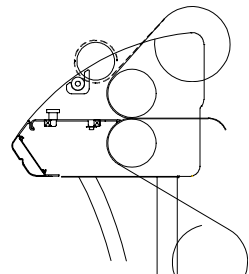

Figure 21

YOU ARE NOW READY TO FEED IMAGES.

6.5 Decaling without liner

Preparation:

Select the films that you will use on the top and bottom of the images, it is advisable to use slightly wider width films compared to the print width. This way the print can be trimmed with a border, so as to reduce waste, but be enough to leave a border. Place the material rolls into the machine with the adhesive facing you. Web as follows:

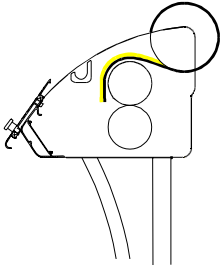

Figure 22

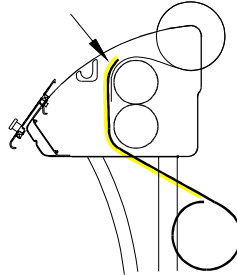

Figure 23

Linerless films:

1. Pull the film down from the upper unwind position and place the film evenly over the top roller.
2. Pull the film from the lower unwind position and stick them together on the top roller.
3. Press the laminates into the nip using the provided leader board.
4. Replace the infeed table.
5. **ALWAYS INSTALL THE IMAGE GUIDE.**

YOU ARE NOW READY TO FEED IMAGES.

6.6 Mounting

This process involves mounting down previously prepared decals onto a substrate. No films or adhesives are used in this process.

To perform this process, it is necessary to remove the Image Guide, you can store the Image Guide in the machine stand (See fig. 9)

6.6.1 To mount decals onto a substrate

Place the mounting board on a flat surface. Lay your image face down on the mounting board and expose approximately 25 mm (1") of the adhesive by peeling back the release paper along one of the edges. Fold the release paper back making an even crease.

Turn the image over and carefully position the exposed adhesive edge of the image squarely onto the board.

Once positioned correctly, press the image firmly down onto the exposed adhesive from the centre toward the edges to ensure smooth surface. This is the edge that will be fed into the rollers first.

Ensure that the nip setting of the rollers corresponds to the board thickness.

Push the edge of the board into the rollers and depress the foot switch until the board and image are just caught by the nip.

Flip the un-tacked portion of the image over the top roller with one hand so that the release paper can be peeled off the image with the other hand. Depress the foot switch to feed the board through the rollers. At this point, continuous run can be selected by pressing one of the speed settings.



Take care that the rollers do not grab the liner

When the end of the board is near the nip, you may want to slow the machine down. To do this, just press the foot switch to enter slow mode. Releasing the foot switch will stop the machine.

Remove the mounted image from the rear of the laminator and trim it if necessary. If the board is accidentally sent in too far at first, the release liner will get caught and will be impossible to pull back. In this case, stop and reverse the motor until the liner can be pulled away. The image must be held against the roller while the board feeds through to prevent wrinkles. As the process becomes more familiar, the speed of the laminator may be increased to make the process more efficient.



Take care that the release liner does not trip the optical safety system.

Note:

Only hard boards (PVC, Polystyrene, MDF, hard board, etc.) that are of the same thickness as the nip settings should be used, otherwise damage to the rollers can occur.

6.7 Encapsulating

This process involves completely sealing an image between two heat-activated films.

Once the machine reaches the operating temperature, the laminator may be stopped, the top roller raised and webbed as per the following photographs and diagrams, refer to the Temperature/Speed chart on page 16 for settings and recommended film combinations.

Preparation:

Note:

Check if the film widths of the lower and upper web are the same!

It is advisable to use slightly wider films compared to the print width. This way the print can be trimmed with a border and not too much film waste is generated, Mount rolls onto the unwind shafts with adhesive facing you. Web as follows:

1. Remove the image guide and the infeed table.
2. Pull the film evenly over the top roller and across the face of the rollers.
3. Split the film from the release liner and pull the film evenly across the face of the rollers.
4. Pull the film up from the bottom unwind station and over the face of the top laminating roller. The films will then heat and stick together.

Note:

Keep the film under tension (turning the top unwind manually) to prevent the photoelectric eyes being tripped.

5. Place the feed table into position, and set the roller nip to 1/16" (2mm) to accommodate for the thickness of the leaderboard.

Note:

Use the 2mm thick leader-board supplied with the machine.

6. Depress the foot switch and then using the provided leader-board push the films into the nip of the rollers. Using the foot switch, advance the leader between the pull rollers until the end comes out of the pull-rollers. Release the foot pedal and set the nip knob to 0mm.
7. Moving to the rear of the laminator, with the film and leaderboard hanging out of the machine, cut off the leaderboard from the front of the laminator, run the film until the output is wrinkle free. Best results will be obtained when the film unwind tension is zero or very light.
Wrinkles, visible on the roller face do not show on the output.
8. Refit the image guide on the infeed table.

YOU ARE NOW READY TO FEED IMAGES.

6.8 Pre-Coating

This process is used to coat substrates with a self-adhesive coating onto which images can be mounted. The same process is used to create a carrier board (sled).

Preparation:

Mount the roll of self-wound pressure sensitive adhesive onto the top unwind of the laminator with the exposed adhesive facing you.



Have a leader board ready of the same thickness as the boards to be coated.

1. Pull the adhesive down from the top unwind station and over the top roller evenly, and down across the face of both main rollers. Remove the infeed table and the Image Guide for a moment to do this.
2. Measure the thickness of the board(s) to be coated, and select the correct nip setting.
3. Press the foot switch and, using the leader board, push the adhesive into the roller nip. Release the foot switch when the rear edge of the leader board is almost leaving the roller nip.
4. Position the board to be coated into the nip, and choose a speed setting.

Note:

When coating boards, ensure that the next board to be coated follows the previous board without any gaps.



Follow the last board being coated with the leader board once again to allow the final board to clear the laminating rollers and then stop the motor and raise the top roller.

6.9 Mounting using a ProSEAL[®] Mounting Board

1. Refer to the instruction sheet packed with each box of ProSEAL Mounting Boards for specific instructions on mounting with a ProSEAL Board.
2. Also, refer to the instruction sheet for information on Compatible Media, Process Conditions and Technical Information.
3. Place the image to be mounted on the adhesive-coated side of the mounting board (dull side of the board). Cover your print with the “cover sheet” as marked; (included with each box of ProSEAL Mounting Boards); please be sure that the board is completely covered by this sheet.
4. Set the Control Knob to the correct setting that matches the Mounting Board thickness.
5. Insert the board into the inlet opening. Ensure the board will enter centered and straight. A gentle push may be required to start the board into the machine. Hold the edges of the board until it is engaged in the unit and the laminator begins pulling it on its own.
6. The board will feed through the laminator and automatically exit at the rear of the unit. **CAUTION! The board will be hot!** Allow it to lie flat while cooling.

6.10 Mounting and Lamination using a ProSEAL[®] pouch Board.

1. Refer to the instruction sheet packed with each box of ProSEAL Pouch Boards for specific instructions on mounting/laminating with a ProSEAL Board.
2. Also, refer to the instruction sheet for information on Compatible Media, Process Conditions and Technical Information.
3. A ProSEAL Pouch Board consists of a SEAL foam board mounting board with a piece of film on top. The film is sealed to the board along one of the short sides. Carefully examine the board to determine which edge is sealed. Starting at one of the corners, opposite the sealed edge, gently lift and peel back the film. Care should be taken not to break the sealed hinge.
4. Center the image to be laminated on the board and lay the film back over it.
5. Set the Control Knob to the correct setting that matches the Pouch Board thickness.
6. Slowly insert the Pouch Board into the inlet opening. Ensure that the Pouch Board will enter centered and straight. A gentle push may be required to start the board into the machine. Hold the edges of the Pouch board until it is engaged and the laminator begins pulling it on its own.
7. The Pouch Board will feed through the Laminator and automatically exit at the rear of the unit.
8. **CAUTION! The pouch board will be hot!**
Allow it to lie flat while cooling.

Note:

If there is any dirt or adhesive on the surface of the board, it can be removed by dampening a lint free cloth with ISO Propyl Alcohol (IPA) and wiping the surface.



WARNING:

**ALWAYS USE CARE WHEN USING IPA! IPA IS VERY FLAMMABLE!
THE FLASH POINT OF IPA IS 11°C (51.8°F). THE SELF-IGNITION
TEMPERATURE IS 400°C (752°F).**

6.11 Encapsulating with a ProSEAL® Flexible Pouch using a ProSEAL® Carrier Board

1. Refer to the instruction sheet packed with each box of ProSEAL Flexible Pouches for specific instructions on encapsulating.
2. Also, refer to the instruction sheet for information on Compatible Media, Process Conditions and Technical Information.
3. The ProSEAL Flexible Pouch consists of two pieces of film that are hinged at one end, along a short side. Separate the two pieces starting at the end opposite the hinge. Take care not to break the hinged seal.
4. Insert the article to be laminated in the pouch so there is at least a 1/8" (3.5mm) border around each of the sides. This ensures that moisture never reaches the image.
5. Place the pouch with the image on the carrier board included with the Flexible Pouches or ProSEAL Sled carrier. (The ProSEAL Sled is a carrier board to assist in the handling of large Flexible Pouches. It is made of materials that will not damage or cause excessive wear to the ProSEAL Laminators.) Smooth out any wrinkles with the side of the hand or a soft flexible squeegee.
6. Tape the leading edge of the pouch to the sled using masking tape.
7. Adjust the Control Knob to the 3/16" (5mm) setting for the ProSEAL Sled. Be sure that the heat is on. (max. temperature)
8. Insert the carrier board with the Flexible Pouch on top into the inlet opening. Ensure that the carrier board is centered and straight. A gentle push may be required to start the carrier board into the machine. Hold the edge of the carrier board until it is engaged and the Laminator begins pulling it on its own.
9. The carrier board will feed through the Laminator and automatically exit at the rear of the machine.
10. **CAUTION! The carrier board will be hot!**
Allow it to lie flat and cool before removing the tape.

Note:

If there is any dirt or adhesive on the surface of the board, it can be removed by dampening a lint free cloth with ISO Propyl Alcohol (IPA) and wiping the surface.



WARNING:

**ALWAYS USE CARE WHEN USING IPA! IPA IS VERY FLAMMABLE!
THE FLASH POINT OF IPA IS 11°C (51.8°F). THE SELF-IGNITION
TEMPERATURE IS 400°C (752°F).**

7 MAINTENANCE & CLEANING

Cleaning of the Machine

The equipment must be disconnected from the mains before cleaning.

The laminator may be cleaned by the operator with a lint-free cloth, lightly dampen with a mild soap and water solution. Spray-on cleaners are not to be used. No part of the machine is to be immersed in water or other liquids.

Do not use an abrasive cleaner, which can damage the painted surfaces.

Do not allow water or liquids to enter the electrical circuits, which may cause personal injury and / or damage the equipment when power is applied.

Cleaning the roller procedure: Use the Image roll-cleaner to remove the excess adhesive from the rollers. This is best done with the rollers hot. When cleaning the upper roller, place a piece of scrap foam board under the roller to prevent the removed adhesive remnants from falling onto the lower roller.

Note:

For adhesive that is difficult to remove, allow the rollers to cool and use isopropyl alcohol (IPA) and a clean, lint-free cloth. Never pour isopropyl alcohol (IPA) directly onto the unit.



WARNING:

**ALWAYS USE CARE WHEN USING IPA! IPA IS VERY FLAMMABLE!
THE FLASH POINT OF IPA IS 11°C (51.8°F). THE SELF-IGNITION
TEMPERATURE IS 400°C (752°F).**

8 TROUBLESHOOTING

List of common problems and solutions that the user can correct:

Problem	cause	solution
The power LED does not come on, when the machine is switched on.	there is no power	check if the power cable is plugged into the mains wall outlet. check the fuse located on the rear side.
LED power is flashing	the voltage from the supplier is too low	Machine voltage 115V: the incoming voltage must be between 90-130V AC. Machine voltage 230V: the incoming voltage must be between 200-250V AC.
LED Forward is flashing	Drive-motor is in overload	the machine is in overload restart the machine
LED Reverse is flashing	Drive-motor is in overload	the machine is in overload restart the machine

List any output problem that the user can change setting to correct

State for any solutions if "ONLY authorized maintenance personnel must do this".

For technical assistance, please contact your technical service representative (see front cover)

9 GLOSSARY OF TERMS

Decal

An image that has been laminated on top (either heat-activated or pressure-sensitive) with an adhesive backing.

Heat-Activated Laminates

Laminates with a dry adhesive that is activated when heat is applied. Once applied to an image the adhesive forms a strong bond adhering the laminate and the image together.

In-Feed

The side of the laminator from which images are fed.

Leader Board

A piece of foam board (about 4' x 2 inches) used to push films into the nip. Also used for mounting or pre-coating boards to prevent adhesive from getting onto the rollers and sealing edges.

Mil

Refers to the thickness of the laminate in 1/1000ths of an inch.

Mounting

Applying an image onto some kind of foam board or substrate.

Nip

The spot where the top and bottom rollers meet.

Out-Feed

The side of the laminator from which completed images emerge.

Pre-Coating

The process of coating a substrate with an adhesive mounting film onto which an image can be mounted.

Press

The amount of force in distance put on anything that passes between the top and bottom rollers. Normally a press of .025 is sufficient.

Pressure-Sensitive Laminates

Laminates with a wet adhesive, which forms a bond between the protective laminate and the surface of the image being laminated. Used primarily for fast mounting applications and recommended for heat-sensitive thermal and photographic prints.

Release Liner

The backing on a pressure-sensitive laminate or mounting adhesive. After peeling the release liner off, the adhesive layer becomes exposed.

Sled (Carrier Board)

A piece of smooth, non-crushable board (preferably Masonite) coated with a mounting adhesive and leaving the release liner on to provide the necessary non-stick surface. A piece of foam board can also be used, but it will not have the longevity of the Masonite board. Sleds are used when laminating one side of an image only.

Substrate

The material to which an image is mounted or affixed.

10 LIMITED WARRANTY

SEAL Graphics warrant to the original consumer purchaser that all new Seal® laminators that prove defective in materials or workmanship within the applicable warranty period will be repaired or, at our option, replaced without charge. The applicable warranty shall be one year from date of purchase with the exception of silicone roll coverings that will be six months from date of purchase. This warranty does not apply if it is found that at any time the equipment has not been used for its intended purpose.

"Original consumer purchaser" means the person whom first purchased the product covered by this warranty other than for purpose of resale. The warranty extends to and is enforceable by only the original consumer purchaser, and only for the period (during the applicable term) which the product remains in the possession of the original consumer purchaser.

For more information regarding this warranty, please contact your distributor.

ATTENTION!

CHANGES OR MODIFICATIONS TO THIS UNIT NOT EXPRESSLY APPROVED BY THE PARTY RESPONSIBLE FOR COMPLIANCE COULD VOID THE USER'S AUTHORITY TO OPERATE THE EQUIPMENT.

ATTENTION!

ANY UNAUTHORIZED CHANGES OR MODIFICATIONS TO THIS UNIT WITHOUT OUR PRIOR WRITTEN APPROVAL WILL VOID THE USER'S WARRANTY AND WILL TRANSFER HEALTH AND SAFETY OBLIGATIONS TO THE USER.

Note:

This equipment has been tested and found to comply with the limits for a class A digital device, pursuant to part 15 of the FCC rules. These limits are designed to provide reasonable protection against harmful interference when the equipment is operated in a commercial environment. This equipment generates uses and can radiate radio frequency energy and, if not installed and used in accordance with Owner's Manual, may cause harmful interference to radio communications. Operation of this equipment in a residential area is likely to cause harmful interference in a residential area is likely to cause harmful interference in which case the user will be required to correct the interference at his own expense.

11 INDEX

A
Application Processes 17

B
Board Thickness 5

C
Cleaning 28

D
Dimensions 5

E
Environment Conditions 8

G
Glossary of Terms 30

I
Image Guide 15
interlock basket 17

L
Liability Statement 2

M
Maintenance 28
Max. Speed 5
Max. Working Width 5

N
Nip 5

R
Roller Pressure 5

S
Speed 5
Standardized Symbols 2

T
Technical Specifications 5

W
Weight 5
wind-up idler 15
Workspace Requirements 8